

SPC – PSD

High Linearity Position Sensing Detector with Signal Processing Circuit

Partnumber: S2 – 0171

Description: 2L10_SU65_SPC01

The SiTek 2L10_SU65_SPC01 is a 2L10 PSD with an attached signal processing circuit. The PSD currents are output as bipolar voltages representing the position and intensity of the centroid of a light spot on the PSD. The intensity signal can be used for external normalisation of the position (difference) signal in regard to light intensity dependence. Inputs are available for external adjustment of offset voltages.

In order to obtain maximum precision, high reliability and small size the SPC01 is built using thick film technology and laser trimmed resistors on a 20,5 x 20,5 mm² ceramic substrate. The SPC01 is delivered with surface mount leads.

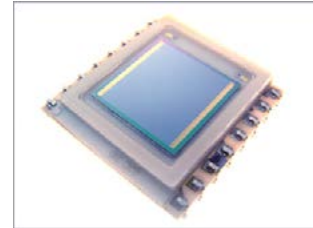

Electrical specification

| Parameter | Symbol | Min. | Typ. | Max. | Unit |
|--|-------------|----------------------|----------------------|-----------------------|-----------------|
| Active area | | | 10 x 10 | | mm ² |
| Position non-linearity | | | 0,3 | 0,8 | % (±) |
| Reverse bias | V_r | | 15 | | V |
| Dark current of PSD @ V_r | I_d | | 100 | 500 | nA |
| Responsivity | r | | 63 | | V/mW |
| Transimpedance | R_f | 9,99*10 ⁴ | 10,0*10 ⁴ | 10,01*10 ⁴ | V/A |
| Amplification in sum and difference stages | A_v | 0,999 | 1 | 1,001 | |
| Output voltage | V_{out} | | | ± 12 | V |
| Output noise | V_{noise} | | 3 | | mVp-p |
| Bandwidth | f_{3dB} | | 400 | | kHz |
| Slew rate | SR | 8 | 13 | | V/μs |
| Supply current | | | 12 | 23 | mA |

Absolute maximum ratings

| Parameter | Symbol | Value | Unit |
|---------------------------|------------|------------|------|
| Power supply voltage | V_s | ± 18 | V |
| Output short-circuit time | | Continuous | |
| Operating temperature | T_{oper} | 70 | °C |
| Storage temperature | T_{stg} | 100 | °C |

Test conditions:

Room temperature 23 °C, Power supply voltage ± 15 V, Light source wavelength 940 nm. Position non-linearity are valid within 80 % of the detector length.

Package:

16 pin ceramic substrate, 20,5 x 20,5 mm², with protective window.

For further information about PSD specific parameters see specification for S2-0003 2L10_SU7.

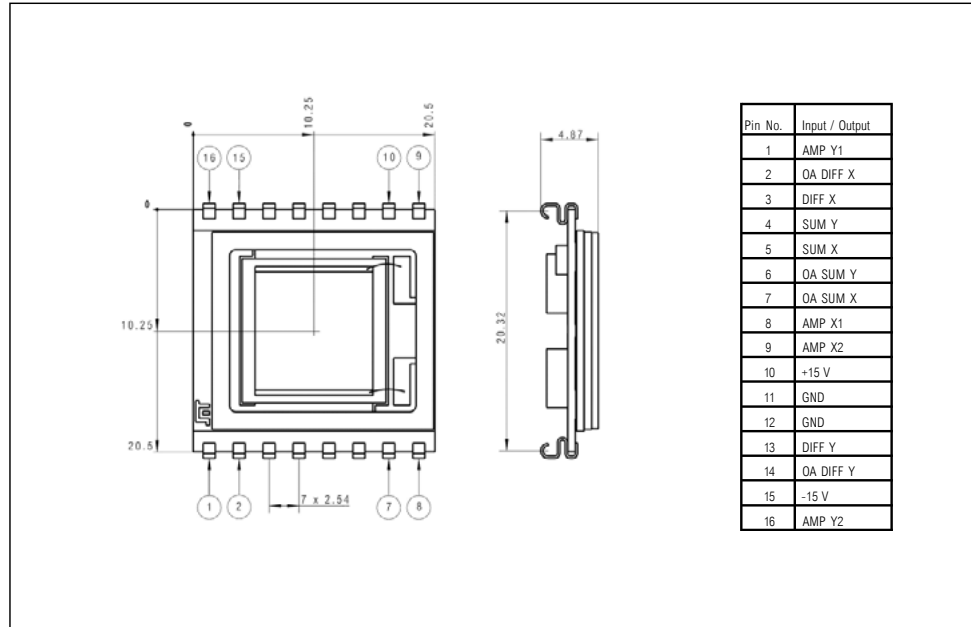

Block schematics

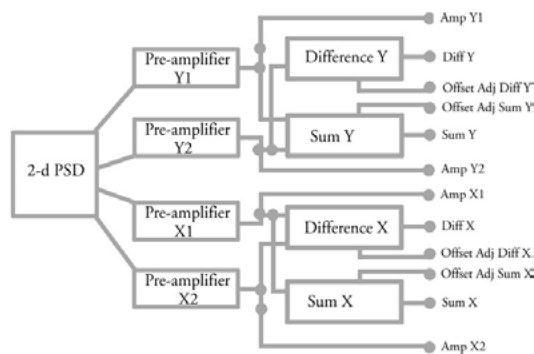

Features

- Analogue outputs of all sum and differential signals
- Laser trimmed resistors
- Inputs for external adjustment of offset voltages
- Good thermal tracking
- Small size

Applications

- Analogue PSD front-end in displacement measuring systems for OEM as well as evaluation purposes.

Application Information

Inputs 2, 6, 7 and 14 are used for external offset compensating voltages. Such a voltage can, as shown in the figure, be derived from a voltage divider and connected to the SPC input through a suitable series resistor.

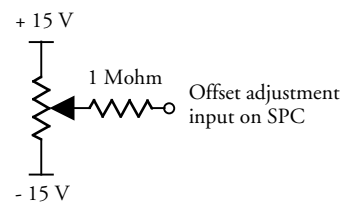

Information in this data sheet is believed to be reliable. However, no responsibility is assumed for possible inaccuracies or omissions. Specifications are subjected to changes without notice.