

➤ PRODUCT DATA SHEET

MPS2x4C2-A-S1.5

Two channel pyroelectric high SNR detector



PRELIMINARY

These sensors detect the typical spectral emission of burning material like wood, oil or plastics. IR Flame detection and NDIR gas analysis are the main application fields.

The absorption of the incident infrared radiation forms a temperature gradient across the detector membrane. Due to the pyroelectric properties of the sensor material, this temperature change is converted into a charge change which can be measured at the electrodes of the sensor chip.

Unlike most competitors' LiTaO₃ chip, Micro-Hybrid's pyroelectric detectors use sensitive elements based on MEMS technology. The pyroelectric element consists of a approximately 0.5 μm thick thinfilm Ceramic Pyroelectrical Material (CPM) mounted on a modified silicon-based membrane which is produced by a DRIE back-etch process. The front electrode is optically transparent allowing infrared radiation to be absorbed by the active area. This area has a broad absorption range from 2 – 15 μm.

FEATURES

- MEMS based CPM membrane
- Broad spectral sensitivity
2 – 15 μm
- High responsivity with modulation frequency up to 200 Hz
- Low microphone effect referring to low membrane mass
- Very low temperature dependence
- Low thermal drift
- Amplified signal

APPLICATIONS

- NDIR gas analysis
- Gas monitoring
- Flame detection

BENEFITS

- Higher precision and SNR due to internal signal amplification
- Higher reading frequencies
- Lower impact of external disturbance like temperature variations
- Short responsive time

PRODUCT DATA SHEET • Pyroelectric detectors • MPS2 low noise | © Micro-Hybrid-Electronic GmbH | 2021-03

All rights reserved. All specifications – technical included – are subject to change without notice. No liability is accepted for any consequential losses, injury or damage resulting from the use of this document or from any omissions or errors herein.

 **INFRARED COMPONENTS
AND SYSTEMS**

Technical data

Technical parameter		Unit
Active area	2 x (0.7 x 0.7)	mm ²
Aperture	2 x (1.5 x 1.5)	mm ²
Mode	current	
Time constant $t_{(0-63\%)}^{\text{thermal}}$	typ. 16	ms
Time constant $t_{(0-63\%)}^{\text{electrical}}$	typ. 2	ms
AC sensitivity ^{1,2,3}	typ. 200000	V/W
Noise density voltage ¹	typ. 50	$\mu\text{V}/\text{Hz}^{1/2}$
Noise equivalent power NEP ^{1,2,3}	typ. 4×10^{-10}	W/Hz ^{1/2}
Specific detectivity $D^*_{1,2,3}$	typ. 4×10^8	$\text{cmHz}^{1/2}/\text{W}$
Microphonic voltage ¹	typ. < 1000	$\mu\text{V}/\text{g}$
Filters	According filter list	
Operation voltage VDD	+2,5 ± 10 %	V DC
Operation voltage VSS-	-2,5 ± 10 %	V DC
Operation current	max. 10	mA
Feedback resistor	10	GΩ
Feedback capacitor	200 ± 50	fF
Operation temperature	-25 ... +80	°C
Housing	T039 (modified)	

Pin out

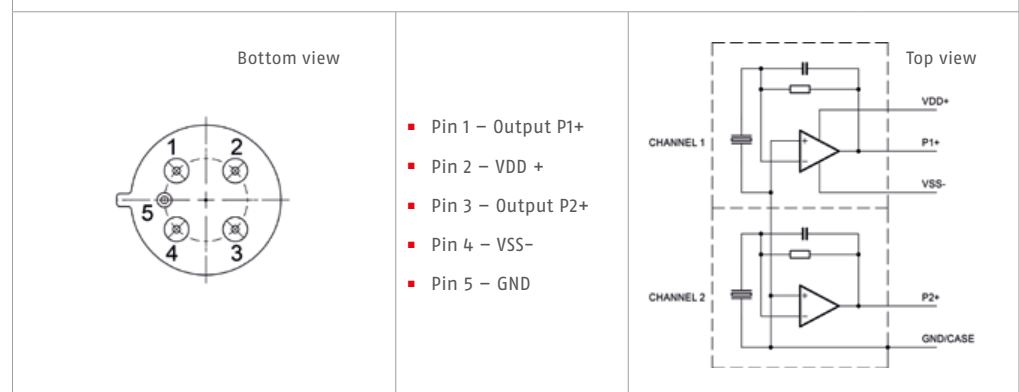

¹ at $T_{\text{amb}} = 25 \text{ }^\circ\text{C}$, 10 Hz, band width 1 Hz
³ on air without windows

² Blackbody $T = 500 \text{ K}$; $E = 38 \text{ W}/\text{m}^2$

Mechanical drawings

Bottom view

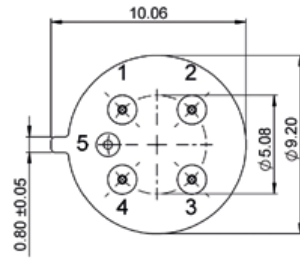

Top view

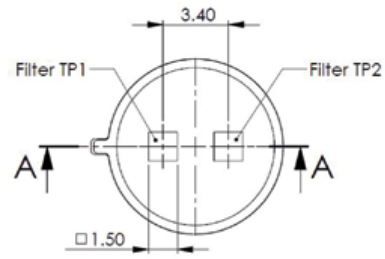

AA

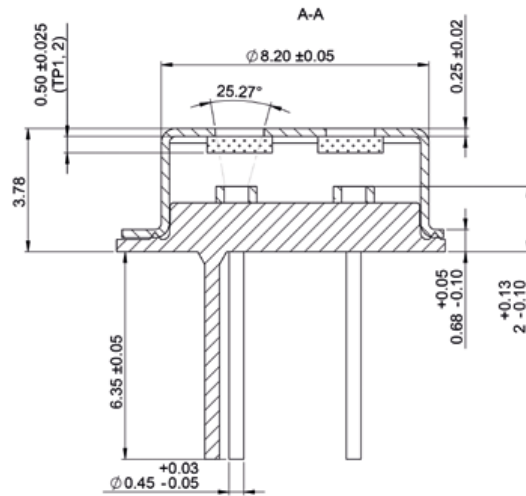

Typical operating characteristics of Pyroelectric detectors › MPS2 Low noise

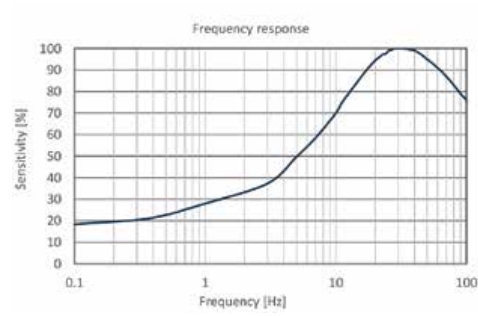

Product overview

Article		Temp. min	Temp. max	Aperture	Channel	Application
PS2x4C2-A-S1.5	on request	-25 °C	80 °C	1.5 x 1.5 mm ²	2	NDIR gas analysis

NOVA IR and **CMOS IR** are companies of Micro-Hybrid Electronic GmbH.