

iC-HTG POWER CW LASER DIODE DRIVER

Rev B1, Page 1/40

FEATURES

- ◆ CW operation with external driver transistor
- ◆ 3 to 24 V power supply
- ◆ Analog modulation frequency of up to 50 kHz
- ◆ Internal programmable logarithmic monitor resistor
- ◆ Operating point setup with a logarithmic resolution of 10 bits
- ◆ Current or power control mode (ACC/APC) configurable
- ◆ A/D converters for analog signals monitoring
- ◆ Serial programming interface (SPI or I²C compliant)
- ◆ Configuration RAM content integrity monitoring
- ◆ Optimized for both N-type and P-type laser diodes
- ◆ Low drop linear regulator for 3.3 V
- ◆ Low current standby mode
- ◆ Temperature monitor
- ◆ Temperature range of -40 to 85 °C

APPLICATIONS

- ◆ Commercial LED/Laser diode modules
- ◆ Safety related CW laser diode drivers
- ◆ Structured-light 3D illumination
- ◆ Laser diode stack control
- ◆ Optical amplification
- ◆ Optical pumping

PACKAGES

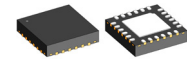

QFN24 4 mm x 4 mm

BLOCK DIAGRAM

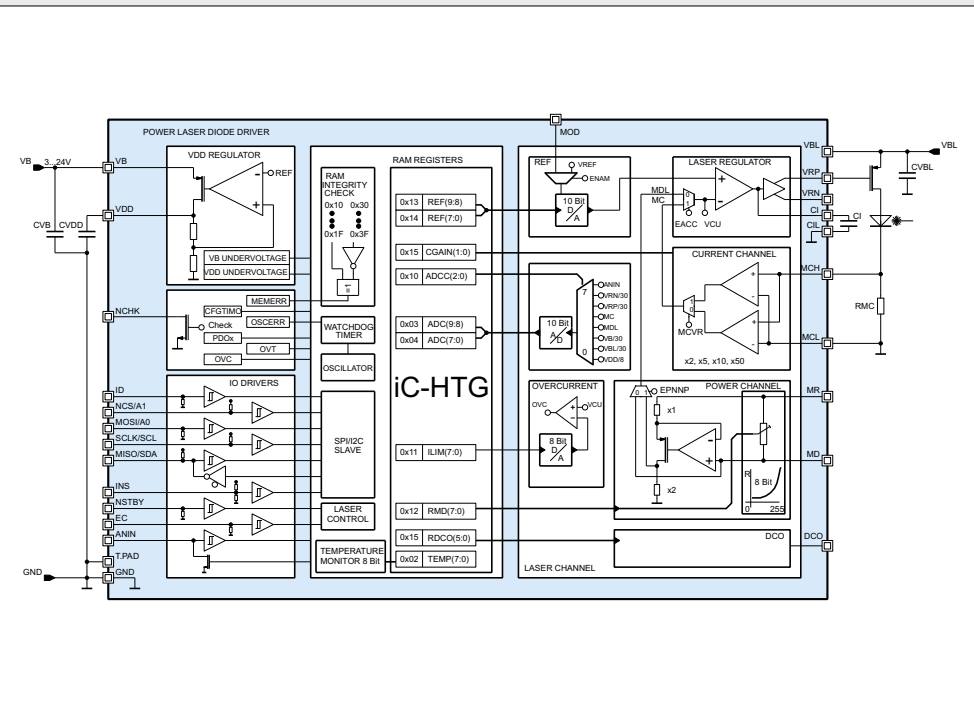

Copyright © 2017, 2020 iC-Haus

iC-HTG

POWER CW LASER DIODE DRIVER

Rev B1, Page 2/40

DESCRIPTION

The CW power laser diode driver iC-HTG can operate a laser diode or LED with an external power transistor and features automatic current (ACC) and power (APC) control. All parameters, including the internal reference voltages, are set via serial communication (I²C or SPI). A 10-bit D/A converter with logarithmic or linear characteristic is used to set the operating point. This allows an operating point resolution better than 1%. In APC mode, the monitor diode photocurrent is used to track the optically emitted power of the laser diode. The voltage across the resistor through which the photocurrent flows is used for feedback in the control loop. An internal 8-bit programmable logarithmic monitor resistor (PLR) or an external monitor resistor can be selected to close the control loop. The PLR ranges from 100 Ω to 407 kΩ with a step width of less than 5%. In ACC mode, the laser diode current can be measured by means of a low impedance shunt resistor. The output power can be analog modulated with a frequency of up to 50 kHz. iC-HTG allows the laser channel to be disabled when an overcurrent threshold has been exceeded. The overcurrent threshold is programmable using an 8-bit linear D/A converter. The temperature monitor measures the internal chip temperature. iC-HTG disables the laser channel when

overtemperature is detected. A number of voltages can be measured with a 10-bit A/D converter:

- V(VB)
- V(VBL)
- V(VDD)
- V(ANIN)
- V(MC)
- V(MDL)
- V(VRP)
- V(VRN)

The current output pin DCO can be used to adjust an external DC/DC converter. Controlling the DC/DC output voltage may optimize the power dissipation of the whole system to extend battery life, for example. In standby mode iC-HTG has a very low current consumption (typ. < 10 μA) while retaining its configuration. The device features for **safe operation** are:

- Configuration RAM content integrity monitored
- Tri-state configuration pins
- Write protection in operating mode
- Safe power-up state

iC-HTG

POWER CW LASER DIODE DRIVER

Rev B1, Page 3/40

CONTENTS

PACKAGING INFORMATION	4	10-BIT LINEAR A/D CONVERTER	21
PIN CONFIGURATION QFN24 4 mm x 4 mm (topview)	4	Sampling input signals at a certain moment	21
PACKAGE DIMENSIONS QFN24-4x4	5	ANIN GENERAL PURPOSE IO PIN	22
ABSOLUTE MAXIMUM RATINGS	6	DC/DC CONVERTER OPTIMIZATION	23
THERMAL DATA	6	DC/DC step down operation: control at voltages lower than power supply	23
ELECTRICAL CHARACTERISTICS	7	DC/DC step up operation: control at voltages higher than power supply	24
OPERATING REQUIREMENTS	11	Extension of system working voltage range	24
SPI and I ² C Interface	11	Efficiency enhancement	24
STANDBY	12	ANALOG MODULATION	25
OPERATION MODE	12	Setting Current Modulation	25
Laser enabling and error handling	12	Analog Modulation in APC mode	26
CONTROL MODES AND LASER DIODE/LED TYPES	13	TEMPERATURE MONITOR AND PROTECTION	27
CI capacitor	13	CONFIGURATION MODE AND MEMORY	
ACC mode	13	INTEGRITY MONITOR	27
ACC mode monitoring the optical power	14	Register map description	28
APC mode	15	Read-only registers with values or states	28
APC mode monitoring the laser current	16	Configuration page (integrity monitored)	28
Other functions	16	Validation page	28
OVERCURRENT MONITOR	17	Possible start-up sequence:	29
WATCHDOG TIMER	17	REGISTER OVERVIEW	29
SERIAL COMMUNICATION INTERFACES	18	PARAMETERS	30
Communication modes	18	Status	30
SPI slave interface	18	Channel configuration registers	32
I ² C slave interface	18	EXAMPLES OF CONFIGURATION	34
8-BIT INTERNAL PROGRAMMABLE LOGARITHMIC MONITOR RESISTORS	19	ACC mode	34
10-BIT LOGARITHMIC D/A CONVERTER	20	APC mode	35
Linear mode	20	APC mode with current monitor or ACC mode with optical power monitor	35
		DESIGN REVIEW: Notes On Chip Functions	38
		REVISION HISTORY	39

iC-HTG POWER CW LASER DIODE DRIVER

Rev B1, Page 4/40

PACKAGING INFORMATION QFN24 4 mm x 4 mm to JEDEC

PIN CONFIGURATION QFN24 4 mm x 4 mm (topview)

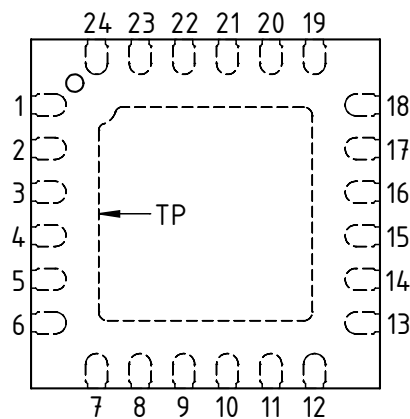

PIN FUNCTIONS

No.	Name	Function
1	NCHK	Check output, active low
2	NSTBY	Standby input, active low
3	NCS/A1	Chip Select, active low / I ² C Address bit 1
4	ID	I ² C address bit 2
5	EC	Enable Channel input
6	MOSI/A0	SPI Master Out Slave In / I ² C Address Bit 0
7	SCLK/SCL	SPI Clock / I ² C Clock
8	MISO/SDA	SPI Master In Slave OUT / I ² C Data
9	ANIN	Analog input for ADC
10	MCH	Current monitor high side
11	MCL	Current monitor low side
12	MOD	Analog modulation
13	CI	Integration Capacitor high side
14	CIL	Integration Capacitor low side
15	VRN	N transistor control
16	VRP	P transistor control
17	VBL	Channel supply
18	MD	Monitor diode
19	MR	Monitor resistor
20	GND	Ground
21	DCO	DC/DC converter trimmer
22	INS	I ² C or SPI selection input
23	VDD	3.3V output supply
24	VB	Power supply

BP(TP) Backside Paddle (GND) ¹⁾

IC top marking: <P-CODE> = product code, <A-CODE> = assembly code (subject to changes).

¹⁾ Connecting the backside paddle is recommended by a single link to GND. A current flow across the paddle is not permissible.

ic-HTG POWER CW LASER DIODE DRIVER

Rev B1, Page 5/40

PACKAGE DIMENSIONS QFN24-4x4

All dimensions given in mm.
This package falls within JEDEC MO-220-VHHD-1.

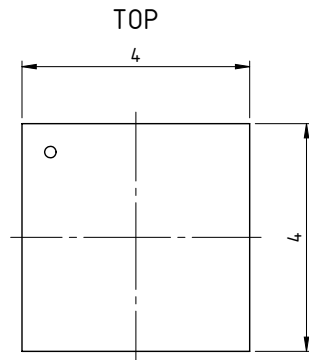
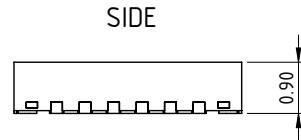

RECOMMENDED PCB-FOOTPRINT

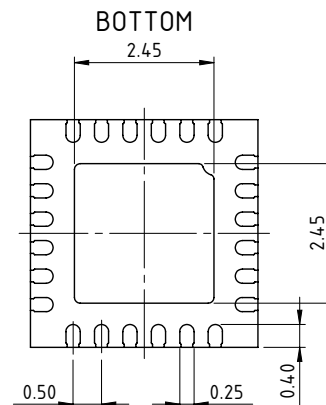
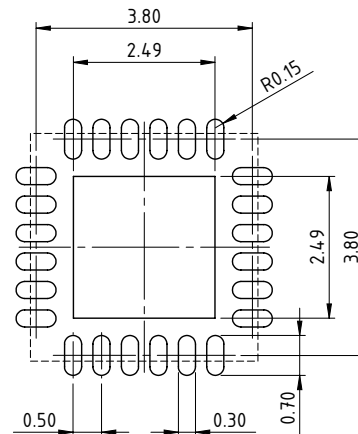

dra_gfn24-1_pack_1_10:1

iC-HTG POWER CW LASER DIODE DRIVER

Rev B1, Page 6/40

ABSOLUTE MAXIMUM RATINGS

These ratings do not imply permissible operating conditions; functional operation is not guaranteed. Exceeding these ratings may damage the device.

Item No.	Symbol	Parameter	Conditions			Unit
				Min.	Max.	
G001	VB	Voltage at VB, VBL		-0.3	30	V
G002	I(VB)	Current in VB, VBL		-20	50	mA
G003	VDD	Voltage at VDD		-0.3	5.5	V
G004	I(VDD)	Current in VDD		-20	1	mA
G005	V()	Voltage at DCO, ANIN, SCLK/SCL, MISO/SDA, MOSI/A0, NCS/A1, DCO, INS, NCHK, CI, MOD, EC		-0.3	5.5	V
G006	V()	Voltage at VRP, VRN, MCH, MCL, NSTBY			30	V
G007	I()	Current in DCO, ANIN, SCLK/SCL, MISO/SDA, MOSI/A0, NCS/A1, DCO, INS, NCHK, CI, VRP, VRN, MCH, MCL, NSTBY, EC		-20	20	mA
G008	V()	Voltage at CIL		-0.3	0.5	V
G009	I(CIL)	Current in CIL	DC current	-900	1	mA
G010	Vd()	ESD Susceptibility at all pins	HBM 100 pF discharged through 1.5kΩ CDM (JEDEC Standard No. 22-C101F)		2 0.5	kV kV
G011	Tj	Operating Junction Temperature		-40	85	°C
G012	Ts	Storage Temperature Range		-40	150	°C

THERMAL DATA

Operating Conditions: VB = 3 ... 24 V (referenced to GND)

Item No.	Symbol	Parameter	Conditions				Unit
				Min.	Typ.	Max.	
T01	Ta	Operating Ambient Temperature Range		-40		85	°C
T02	Rthja	Thermal Resistance Chip/Ambient	Mounted on PCB		25		K/W
T03	RthjTP	Thermal Resistance Chip/Thermal Pad			4		K/W

All voltages are referenced to ground unless otherwise stated.
All currents flowing into the device pins are positive; all currents flowing out of the device pins are negative.

IC-HTG POWER CW LASER DIODE DRIVER

Rev B1, Page 7/40

ELECTRICAL CHARACTERISTICS

Operating Conditions: VB = VBL = 3 ... 24 V (relative to GND), Tj = -40 ... 125 °C unless otherwise stated

Item No.	Symbol	Parameter	Conditions	Min.	Typ.	Max.	Unit
General							
Functionality and parameters beyond the operating conditions (with reference to independent voltage supplies, for instance) are to be verified within the individual application using FMEA methods.							
001	VB	Permissible Supply Voltage	Relative to GND	3		24	V
002	I(VB)	Standby Current at VB	V(NSTBY) ≤ 0.4 V; VB = 3... 11 V VB = 11... 24 V			10 30	μA μA
003	I(VBL)	Standby Current at VBL	V(NSTBY) ≤ 0.4 V; VBL = 3... 11 V VBL = 11... 24 V			10 25	μA μA
004	I(VB)	Supply Current at VB	No load, EC, NSTBY = hi			5	mA
005	I(VBL)	Supply Current at VBL	No load, EC, NSTBY = hi			25	mA
006	V(VB)on	Turn-off threshold at VBL	Increasing VBL	1		2.9	V
007	V(VB)off	Turn-off threshold at VB, VBL	Decreasing VB, VBL	0.8		2.6	V
008	V(VBL)Hys	Power-on hysteresis at VBL		20		500	mV
009	V(VDD)on	Turn-on threshold	Increasing VDD	1.3		2.4	V
010	V(VDD)off	Turn-off threshold	Decreasing VDD	1.2		2.3	V
011	V(VDD)Hys	Power-on hysteresis		20		250	mV
012	V(VB)INITR	RAM memory reset during Standby	NSTBY = lo		1.4*		V
013	RCIL()	Resistor between GND and CIL				20	Ω
014	Vc()lo	Clamp Voltage lo at VB, VBL, VDD, NCHK, NCS/A1, MISO/SDA, MOSI/A0, SCLK/SCL, INS, NSTBY, EC, DCO, CI, MD, MR, MCH, MCL, VRP, VRN, MOD	I() = -10 mA	-1.6		-0.3	V
Transistor Driver VRx, Clx, MCx, MR, MD							
101	C(CI)	Required capacitor at CI	CW Analog Modulation	1000	80		pF pF
102	I(CI)	Charge Current at CI	V(CI) = 0 V, CI regulated	-30		-5	μA
103	V(MCx)	Permissible Voltage at MCH, MCL	EC = hi, NSTBY = hi; MCVR = lo MCVR = hi	0 VBL - 5		0.8 VBL	V V
104	V(MR,MD)	Permissible Voltage at MR, MD	EC = hi, NSTBY = hi; EPNNP = lo EPNNP = hi	0 VDD - 1.2		1.2 VDD	V V
105	I(VRP)hi	VRP Current High	VBL = 3... 8 V, VRP = 0 V VBL = 8... 24 V, VRP = VBL - 8 V			-0.25 -1	mA mA
106	I(VRP)lo	VRP Current low	VBL = 3... 5 V, VRP = VBL VBL = 5... 24 V, VRP = 8 V	10 40			mA mA
107	I(VRN)Hi	VRN current High	VRNHR = 1, VBL = 3... 8 V, VRN = 0 V VRNHR = 1, VBL = 8... 24 V, VRN = 0 V VRNHR = 0, VBL = 4.5... 8 V, VRN = 0 V VRNHR = 0, VBL = 8... 24 V, VRN = 10 V			-0.25 -1 -10 -40	mA mA mA mA
108	I(VRN)lo	VRN current Low	VRNHR = 1, VBL = 3... 8 V, VRN = VBL VRNHR = 1, VBL = 8... 24 V, VRN = 5 V VRNHR = 0, VBL = 3... 8 V, VRN = VBL VRNHR = 0, VBL = 8... 24 V, VRN = 8 V	10 30 10 40			mA mA mA mA
109	V(VRP)	Voltage output range	No load, channel enabled; VBL = 3V VBL = 9V VBL = 15V VBL = 24V	1.9 3 3.5 4.5		3 9 15 24	V V V V

* Projected value by sample characterization

IC-HTG

POWER CW LASER DIODE DRIVER

Rev B1, Page 8/40

ELECTRICAL CHARACTERISTICS

Operating Conditions: VB = VBL = 3 ... 24 V (relative to GND), Tj = -40 ... 125 °C unless otherwise stated

Item No.	Symbol	Parameter	Conditions	Min.	Typ.	Max.	Unit
110	V(VRN)	Voltage output range	No load, channel enabled;				
			VRNHR = lo, VBL = 3 V	0		1	V
			VRNHR = lo, VBL = 9 V	0		6.5	V
			VRNHR = lo, VBL = 15 V	0		12	V
			VRNHR = lo, VBL = 24 V	0		19	V
			VRNHR = hi, VBL = 3 V	1.8		3	V
			VRNHR = hi, VBL = 9 V	2.3		9	V
			VRNHR = hi, VBL = 15 V	3.1		15	V
		VRNHR = hi, VBL = 24 V	4		24	V	
111	Ten	Time to laser enabled	NSTBY lo → hi, no load at VDD, V(VDD) 0 to 90%, CVDD = 1 μF		1.3		ms
Programmable Resistor							
201	Rmda	Resistor at MD and MR pin	RMD(7:0) = 0xFF, DISP = 0 RMD(7:0) = 0x00, DISP = 0	350 0.154	500 0.220	650 0.286	kΩ kΩ
202	Tk	Temperature coefficient			-500		ppm/K
203	ΔR	Resistor increment	$\Delta R = \frac{R(n+1) - R(n)}{R(n)}$	1	3.3	7	%
204	Ileak(MDA)	MD, MR leakage current	DISP = 1	-2		2	μA
D/A Converter							
301	RES(DAC)	D/A Converter Resolution				10	bit
302	ΔV	Voltage increments	LINLOG = 0, $\Delta V = \frac{V(n+1) - V(n)}{V(n)}$	0.05	0.235	1	%
303	ΔV	Voltage increments	LINLOG = 1		1		mV
304	V(DAC)	D/A Converter	LINLOG = 0/1;				
			REF(9:0) = 0x000 lowest value REF(9:0) = 0x3FF highest value	0.09 1.00	0.10 1.10	0.12 1.25	V V
305	V(REF)	D/A Converter	V(MOD) = 1.1 V, analog modulation enabled, LINLOG = 0/1;				
			REF(9:0) = 0x000 lowest value REF(9:0) = 0x3FF highest value	0.09 1.00	0.10 1.10	0.12 1.25	V V
306	G()	Gain Factor	ACC mode;				
			CGAIN(1:0) = 00	1.5	2	2.5	
			CGAIN(1:0) = 01	3	5	7.9	
			CGAIN(1:0) = 10	6.1	10	15.9	
		CGAIN(1:0) = 11	35	50	70		
Check Output NCHK							
401	Vs(lo)	Saturation Voltage lo at NCHK	I(NCHK) = 1.0 mA			0.4	V
402	Isc(lo)	Short Circuit Current lo at NCHK	V(NCHK) = 0.4 ... 3.3 V	3		33	mA
403	Iik()	Leakage Current at NCHK	NCHK = 1, V(NCHK) = 0 ... 5.5 V	-10		10	μA
Series Regulator Output VDD							
501	V(VDD)	Regulated output voltage	I(VDD) = -10 ... 0 mA, NSTBY = hi	3		3.5	V
502	V(VB,VDD)	Voltage Drop between VB and VDD	VB = 3 V, I(VDD) = -10 ... 0 mA, NSTBY = hi		300	690	mV
503	C(VDD)	Capacitor at VDD	Ri(C) < 1 Ω	1		3.3	μF
504	Tvdd	Settling time VDD	NSTBY lo → hi, no load at VDD, V(VDD) 0 to 90%, CVDD = 1 μF			1	ms
505	Isc(VDD)	Short circuit current at VDD	VDD Connected to GND	-125			mA
Digital inputs/output NCS/A1, MISO/SDA, MOSI/A0, SCLK/SCL, ID, NSTBY, EC, ANIN							
601	Vt(jhi)	Input Threshold Voltage hi at NCS/A1, MISO/SDA, MOSI/A0, SCLK/SCL, ID, NSTBY, EC, ANIN	MISO/SDA as input with INS = hi			2	V
602	Vt(jlo)	Input Threshold Voltage lo at NCS/A1, MISO/SDA, MOSI/A0, SCLK/SCL, ID, NSTBY, ANIN, EC, ANIN	MISO/SDA as input with INS = hi	0.8			V

IC-HTG POWER CW LASER DIODE DRIVER

Rev B1, Page 9/40

ELECTRICAL CHARACTERISTICS

Operating Conditions: $V_B = V_{BL} = 3 \dots 24$ V (relative to GND), $T_J = -40 \dots 125$ °C unless otherwise stated

Item No.	Symbol	Parameter	Conditions	Min.	Typ.	Max.	Unit
603	Vt(hys)	Hysteresis at NCS/A1, MISO/SDA, MOSI/A0, SCLK/SCL, ID, NSTBY, ANIN, EC	$V_t(\text{hys}) = V_t(\text{hi}) - V_t(\text{lo})$	50			mV
604	Ipd()	Pull-Down Current at MOSI/A0, EC	$V() = 0.4$ V ... VDD	1		50	µA
605	Ipd()	Dynamic Pull-Down Current at NSTBY	$V() = 0.4$ V ... $V_t(\text{lo})$ $V() = V_t(\text{hi}) \dots V_B$	1 0.5		50 15	µA µA
606	Rpu()	Pull-Up Resistor at NCS/A1, SCLK/SCL		80	150	260	kΩ
607	Rpu()	Pull-Up Resistor at MISO/SDA	INS = lo INS = hi	8 53	20 100	50 174	kΩ kΩ
608	Er()	Safe enable threshold voltage at INS	Rising Falling	52 30	54 32	56 34	% VDD % VDD
609	Voc()	Open Circuit Voltage at INS		40	41	45	% VDD
610	Ri()	Internal Resistance at INS		170	250	360	kΩ
611	Isc(lo)	Short Circuit current lo at MISO/SDA	INS = lo, $V(\text{MISO/SDA}) = 5.5$ V	-40		-4	mA
612	Vs(lo)	Saturation Voltage lo at MISO/SDA	INS = lo, $I(\text{MISO/SDA}) = 2$ mA			0.4	V
613	Isc(lo)	Short Circuit current lo at ANIN	ANIN as output, $V(\text{ANIN}) = 5.5$ V	-40		-4	mA
614	Vs(lo)	Saturation Voltage lo at ANIN	ANIN as output, $I(\text{ANIN}) = 2$ mA			0.4	V
A/D Converter							
701	Ton	Converter initialization time	ENAD changes from 0 to 1			500	µs
702	Tconv	Conversion time	ENAD 0→1 to DRDY 0→1			140	µs
703	RES(ADC)	A/D Converter Resolution				10	bit
704	RAC	Relative Accuracy		-1		+1	LSB
705	VZS()	Zero Scale Voltage	ADC(9:0) = 0x000		0		V
706	VFS()	Full Scale Voltage	ADC(9:0) = 0x3FF	1.0	1.1	1.2	V
707	VDDM()	VDD Measurement	$V_{DD} = 3.3$ V, ADCC(2:0) = 000, ENADCDIV = 1	334	368	402	LSB
708	VBML()	VBL Measurement	$V_{BL} = 24$ V, ADCC(2:0) = 001, ENADCDIV = 1	654	720	786	LSB
709	VBM()	VB Measurement	$V_B = 24$ V, ADCC(2:0) = 010, ENADCDIV = 1	654	720	786	LSB
710	MDLM()	MDL Measurement	$ V(\text{MD}) - V(\text{MR}) = 0.5$ V, ADCC(2:0) = 011	413	455	497	LSB
711	MCM()	$V(\text{MCH}) - V(\text{MCL})$ Measurement	$V(\text{MCH}) < 0.8$ V, $V(\text{MCH}) - V(\text{MCL}) = 0.25$ V, CGAIN(1:0) = 000, ADCC(2:0) = 100	320	480	640	LSB
712	VRNM()	VRN Measurement	$V_{RN} = V_{BL} = V_B = 12$ V, ADCC(2:0) = 101, ENADCDIV = 1	330	365	402	LSB
713	VRPM()	VRP Measurement	$V_{RP} = 24$ V, ADCC(2:0) = 110, ENADCDIV = 1	658	724	790	LSB
714	ANINM()	ANIN Measurement	ANIN = 0.5 V, ADCC(2:0) = 111	409	451	493	LSB
Overtemperature							
B01	Toff	Overtemperature Shutdown	Rising temperature	130		170	°C
B02	Ton	Overtemperature Release	Falling temperature	125		165	°C
B03	Thys	Hysteresis	Toff – Ton	3			°C
Temperature Monitor							
C01	Trange	Temperature Measurement Range		-40		125	°C
C02	Tresol	Temperature Measurement Resolution			1		°C
C03	TEMP	Temperature Value Ranges	$T_J = 125$ °C $T_J = -40$ °C	160 0		190 15	LSB LSB
DCO Output							
D01	Isc(hi)	DCO Output Current	$V(\text{VDD}) = 3 \dots 3.5$ V, $V(\text{DCO}) < 1.4$ V, RDCO = 0x3F	-175	-130	-85	µA

iC-HTG POWER CW LASER DIODE DRIVER

Rev B1, Page 10/40

ELECTRICAL CHARACTERISTICS

Operating Conditions: $V_B = V_{BL} = 3 \dots 24$ V (relative to GND), $T_j = -40 \dots 125$ °C unless otherwise stated

Item No.	Symbol	Parameter	Conditions	Min.	Typ.	Max.	Unit
D02	I _{leak}	Leakage Current at DCO	RDCO = 0x00 or NSTBY = lo, V(DCO) = 0 ... V(VDD)	-1		1	µA
D03	I(DCO)LSB	I(DCO) Resolution	V(DCO) < 1.4 V	1.3	2	2.7	µA
Oscillator							
E01	F _(osc)	Oscillator Frequency	NSTBY = hi	100	200	400	kHz
E02	T _(CFGTIMO)	Configuration Mode Timeout	MODE(1:0) = 10, count of oscillator pulses		16400		Pulses
E03	tWDT	Watchdog Timeout	NSTBY = hi	20		120	µs

IC-HTG POWER CW LASER DIODE DRIVER

Rev B1, Page 11/40

OPERATING REQUIREMENTS: SPI and I²C Interface

Operating Conditions: $V_B = 3 \dots 24 \text{ V}$, $T_j = -40 \dots 85^\circ \text{C}$

Item No.	Symbol	Parameter	Conditions	Min.	Max.	Unit
SPI / I²C Interface Timing						
I001	tsCCL	Setup Time: NCS/A1 hi → lo before SCLK lo → hi	INS = lo	20		ns
I002	tsDCL	Setup Time: MOSI/A0 stable before SCLK/SCL lo → hi	INS = lo	20		ns
I003	thDCL	Hold Time: MOSI/A0 stable after SCLK/SCL lo → hi	INS = lo	5		ns
I004	tCLH	Signal Duration SCLK/SCL hi	INS = lo INS = hi	5 1250		ns ns
I005	tCLL	Signal Duration SCLK/SCL lo	INS = lo INS = hi	5 1250		ns ns
I006	thCLC	Hold Time: NCS/A1 lo after SCLK/SCL hi → lo	INS = lo	5		ns
I007	tCSH	Signal Duration NCS/A1 hi	INS = lo	20		ns
I008	tpCLD	Propagation Delay: MISO/SDA stable after SCLK/SCL hi → lo	$V(VDD) > 3 \text{ V}$, $C_{load} = 10 \text{ pF}$, no external pull-up	0	30	ns
I009	f(SCLK)	SPI clock frequency			10	MHz
I010	f(SCL)	I ² C clock frequency			400	kHz

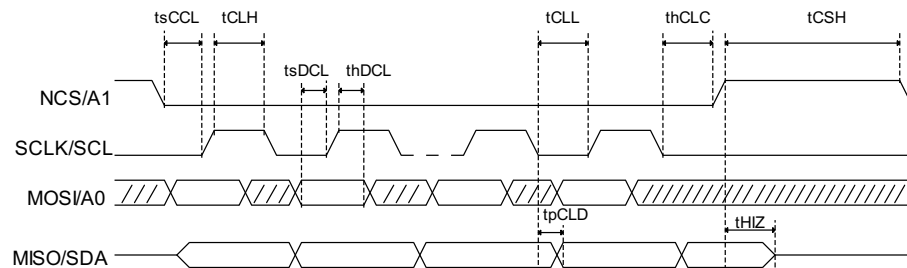

Figure 1: SPI / I²C interface timing

iC-HTG POWER CW LASER DIODE DRIVER

Rev B1, Page 12/40

STANDBY

iC-HTG enters standby mode by setting pin NSTBY low. In standby mode with no current drained from pin VDD, the current consumption at VB is reduced to e.g. 10 μ A max. (cf. *Electrical Characteristics No. 002*) and the chip retains its RAM configuration.

In order to exit standby mode, pin NSTBY must be set to hi, e.g. to the supply voltage at VB. When connecting it to VB, a resistor of at least 1 k Ω in series is required

for protection. As VDD is switched off in standby mode, it cannot be used to exit standby.

After wake-up (pin NSTBY's rising edge), the internal regulated supply voltage at VDD returns to its nominal value at a rate depending on the capacitor connected to pin VDD (cf. *Electrical Characteristics No. 504*).

More information about the start-up procedure on page 29.

OPERATION MODE

iC-HTG has two main modes: configuration mode and operation mode. The mode is set in register MODE(1:0).

MODE(1:0)		Addr. 0x1C; bit 1:0	R/W 01
Code	Function		
00	Not allowed, signaled as memory error		
01	Chip set in operation mode (apply configuration, latch transparent)		
10	Chip set in configuration mode (hold previous configuration)		
11	Not allowed, signaled as memory error		

Table 5: Select configuration or operation mode

The internal parameters of iC-HTG are set in configuration mode via I²C or SPI using a microcontroller. In this mode the configuration memory can be written and read back without changing the current configuration state of iC-HTG. Once the configuration is verified and accepted as valid, iC-HTG can be switched to operation mode and the new configuration will be activated. More information about configuration and operation modes and the serial communication interface on pages 27 and 18.

In operation mode, the driver is enabled by setting pin EC to hi. Setting register bit DISC to '1' disables the driver. If either pin EC is low or register bit DISC is high, the laser is disabled.

DISC		Addr. 0x10; bit 3	R/W 1
Code	Function		
0	Channel can be enabled by pin EC		
1	Channel cannot be enabled by pin EC		

Table 6: Disable channel

The iC-HTG can be configured for two control modes: laser-light power-control (APC) and laser current control (ACC). The control mode is selected by setting the EACC register. More about control modes is on page 13.

EACC		Addr. 0x10; bit 0	R/W 0
Code	Function		
0	APC mode enabled (laser power control)		
1	ACC mode enabled (laser current control)		

Table 7: Select APC or ACC

Laser enabling and error handling

Setting register bit DISC to '0' enables the laser channel.

The input pin INS needs to be high or low. With an open floating INS pin a corresponding internal error signal is generated (INSOPEN).

Internal INSOPEN error signal and status errors shown in Figure 2 disable the laser channel. Every change in the STATUS0 or STATUS1 registers is signaled at pin NCHK, unless the error event is masked by the corresponding error mask bit.

iC-HTG POWER CW LASER DIODE DRIVER

Rev B1, Page 13/40

Register	Address	Bits	Default	Description
INITRAM	0x00	0	R/O	RAM initialized
PDOVDD	0x00	1	R/O	Power down event at VDD
MEMERR	0x00	2	R/O	RAM memory validation error
OVT	0x00	3	R/O	Overtemperature event
PDOVBL	0x00	4	R/O	Power down event at VBL
OVC	0x00	5	R/O	Overcurrent
OSCERR	0x00	6	R/O	Oscillator error (watchdog set)
CFGTIMO	0x00	7	R/O	Configuration mode timeout event
MAPC	0x01	0	R/O	Channel current state read back
MONC	0x01	1	R/O	Channel enabled at least once (latched)
EC	0x01	2	R/O	EC pin current state read back
NMCOK	0x01	3	R/O	Current feedback status

Table 8: Status registers overview

In order to enable the channel, the error events must be acknowledged. Acknowledging an error is accomplished by reading the corresponding STATUS register. After a power-on, PDOVDD and INITRAM errors will be set, therefore it is required to read the registers STATUS0 and STATUS1 after each power-on.

Exiting standby mode does not reset the RAM, but does set the PDOVDD status bit. Therefore STATUS0 must be read once after each standby to re-enable the laser channel.

In case of an overcurrent (OVC) or an overtemperature (OVT) event, the laser channel is disabled.

A memory error event (MEMERR) or a configuration timeout error event (CFGTIMO) also disables the laser

channel. More information about the memory error is on page 27. The conditions to enable the laser channel are shown in Figure 2.

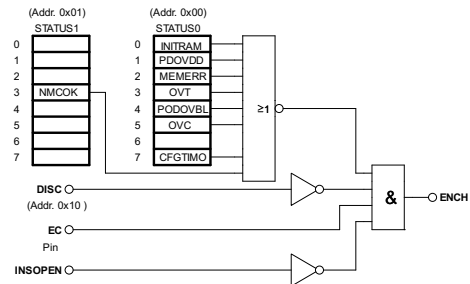

Figure 2: Laser control logic

CONTROL MODES AND LASER DIODE/LED TYPES

iC-HTG features no integrated driver transistor. External power transistors (P-channel or N-channel) can be driven, connecting the gate of the transistor to pins VRP or VRN. Another possibility is to control a DC/DC converter directly, providing the best power efficiency.

iC-HTG can be configured for two control modes: laser power control (APC) and laser current control (ACC). The control mode is selected by setting bit EACC.

EACC	Addr. 0x10; bit 0	R/W 0
Code	Function	
0	APC mode enabled (laser power control)	
1	ACC mode enabled (laser current control)	

Table 9: Select APC or ACC

CI capacitor

For most applications a CI capacitor of at least 220 pF is recommended in order to ensure the stability of the control loop. The exact amount of capacitance needed depends on many factors such as PCB layout, output transistor, laser diode, and current range. The CI capacitor is used for APC and ACC. In APC configurations where the transistor gate is controlled by VRP, an additional capacitor (typ. 10 nF) from VRP to CI can further improve the control loop stability.

ACC mode

In ACC mode, the laser current is controlled. ACC mode is selected by setting bit EACC to '1'. In this mode, an external shunt resistor (RMC) is used to monitor the laser diode current. The voltage drop across this shunt resistor serves as feedback to the control

IC-HTG POWER CW LASER DIODE DRIVER

Rev B1, Page 14/40

loop. To feed the current voltage drop to the control loop, the shunt resistor must be connected to the pins MCH and MCL. The voltage drop $MCx = V(MCH) - V(MCL)$ needs to be positive. This voltage drop is internally amplified by a factor of 2, 5, 10 or 50. This factor can be selected using the register CGAIN(1:0). The resistor has to be chosen so that the value of the voltage drop multiplied by the amplification factor does not exceed the higher value of the reference generated with the 10-bit logarithmic D/A converter. This value is typically 1 V. More on this is on page 20.

CGAIN(1:0)		Addr. 0x15; bit 7:6	R/W 00
Code	Function		
00	Amplification set to x2		
01	Amplification set to x5		
10	Amplification set to x10		
11	Amplification set to x50		

Table 10: MCx voltage drop amplification

Depending on the output configuration and the position of RMC in the current path, the voltage between pins MCH and MCL will be in between 0 and 5 V or in the range from $VBL - 5V$ to VBL . The MCx voltage range can be set with the register bit MCVR.

MCVR		Addr. 0x13; bit 2	R/W 0
Code	Function		
0	MCx Voltage Range is 0 to 5V		
1	MCx Voltage Range is $VBL - 5V$ to VBL		

Table 11: MCx voltage range

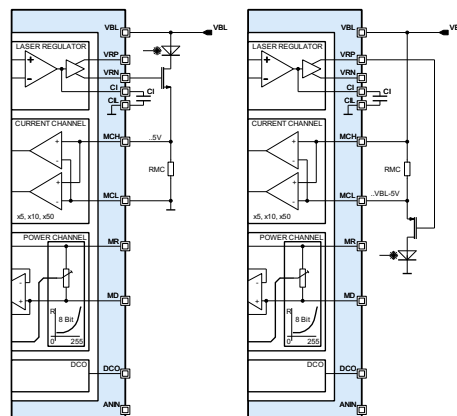

Figure 3: Operation in ACC mode with N-channel or P-channel output transistor. $EACC = 1$, $MCVR = 0$ and $MCVR = 1$

In ACC mode the register EPNNP is ignored.

Examples of connecting RMC using N-channel and P-channel transistors are shown in Figure 3.

By using the output transistor as a source follower like in Figure 3, the system shows increased stability and the CI capacitor can be smaller. This is recommended for analog modulation with pin MOD. There are many other configurations possible depending on laser type, transistor, and voltage range. More information on page 34.

ACC mode monitoring the optical power

In ACC mode, the optical power can be measured using a laser with an integrated photodiode (N-type or P-type). Connecting the photodiode to pin MD, a proportional voltage to the photocurrent can be measured with the 10-bit linear A/D converter. Two examples of ACC mode using a laser with integrated photo diodes are shown in Figure 4.

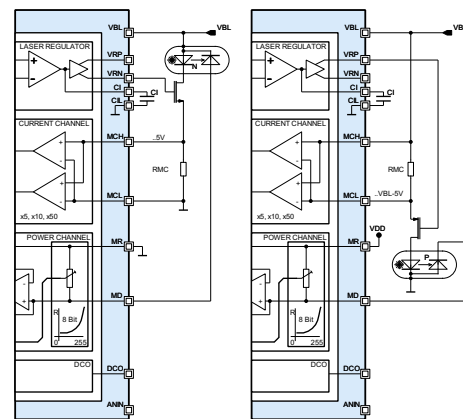

Figure 4: Example of ACC monitoring the optical power $EACC = 1$. In the left setup $MCVR = 0$ and $EPNNP = 0$ while in the right setup, $MCVR = 1$ and $EPNNP = 1$

More examples of configurations for this application on page 34.

Depending on the type of laser, N or P, bit EPNNP has to be set to '0' or '1'.

IC-HTG POWER CW LASER DIODE DRIVER

Rev B1, Page 15/40

EPNNP		Addr. 0x13; bit 7	R/W 0
Code	Function		
0	N-type laser		
1	P-type laser		

Table 12: Enable P- or N- type laser

The monitor current is measured via its voltage drop across the internal 8-bit programmable logarithmic resistor PLR (more information about the PLR on page 19). If an external resistor shall be used, it must be connected to pins MD and MR and the internal resistor PLR must be disconnected by setting bit DISP to '1'.

DISP		Addr. 0x10; bit 2	R/W 0
Code	Function		
0	PLR enabled		
1	PLR disabled		

Table 13: Enable/disable PLR

To measure the optical power, register ADCC(2:0) has to be set to 0b011. Thus the internal voltage MDL = $|V_{MD} - V_{MR}|$ will be selected as an input for the 10-bit A/D converter.

ADCC(2:0)		Addr. 0x10; bit 7:5	R/W 000
Code	Function		
000	ADC sourced by $V(VDD) \div 8$ (3 .. 5.5V)		
001	ADC sourced by $V(VBL) \div 30$ (3 .. 24V)		
010	ADC sourced by $V(VB) \div 30$ (3 .. 24V)		
011	ADC sourced by $V(MDL)$ (0 .. 1.1V)		
100	ADC sourced by $V(MC)$ (0 .. 1.1V)		
101	ADC sourced by $V(VRN) \div 30$ (0 .. 24V)		
110	ADC sourced by $V(VRP) \div 30$ (0 .. 24V)		
111	ADC sourced by $V(ANIN)$ (0 .. 1.1V)		

Table 14: ADC source selection

APC mode

In APC mode, the optical laser power is controlled. APC mode is selected by setting bit EACC to '0'. In this mode, the monitor diode current is used as feedback in the laser power control loop. To introduce the monitor diode current in to the feedback control loop pins MR and MD are used. An internal, 8-bit programmable logarithmic monitor resistor (PLR) can be used in APC mode and is controlled by register RMD(7:0). It is also possible to use an external monitor resistor connected to pins MR and MD. If register bit DISP is '0', the PLR is present. If DISP is '1', the PLR is disabled and an external monitor resistor must be used. The PLR feature a wide logarithmic resistor range from 100Ω to 500kΩ in steps of typically 3.3%. This covers a wide range of monitor currents. More information about the PLR on page 19.

For fine-tuning the optical power, the reference voltage is set with a 10-bit logarithmic D/A converter, which is configurable using register REF(9:0).

REF(9:8)		Addr. 0x13; bit 1:0	R/W 0x000
REF(7:0)		Addr. 0x14; bit 7:0	R/W 0x000
Code	Function		
0x000	Regulator reference voltage set to minimum voltage		
...	Regulator reference voltage set to		
	$V_{ref} = V_{ref0} (1 + \frac{\Delta V_{ref}(\%)}{100})^{n+1}$, n from 0 to 1023		
0x3FF	Regulator reference voltage set to maximum voltage		

Table 15: Channel regulator voltage reference

With EPNNP = 1 there is a signal level converter in the control loop, which references the values coming from the PLR to GND. This is necessary because the logarithmic D/A is referenced to GND. In addition this signal level converter adds a 1:2 ratio between the voltage at PLR and at the logarithmic D/A converter i.e. 1.1V at the logarithmic D/A are 0.55V at the PLR.

This converter has a voltage range that goes typically from $V_{ref0} = 0.1$ to $V_{refmax} = 1.1V$, allowing an operation resolution of typically $\Delta V_{ref} = 0.235\%$. More information on the logarithmic D/A converted on page 20. For calculating the minimum value for the monitor feedback current (I_{mon}), $V_{ref}(0x00, \text{max. value})$ (cf. *Electrical Characteristics No. 304*) and $R_{mda}(RMDx = 0xFF, \text{min. value})$ (cf. *Electrical Characteristics No. 201*) are used.

$$I_{mon}(min) = \frac{V_{ref}(0x00, \text{max})}{n \times R_{mda}(RMDx = 0xFF, \text{min})} = \frac{0.11}{350000} = 0.31 \mu A$$

n = 2 for EPNNP = 1
n = 1 for EPNNP = 0

To calculate the maximum value of I_{mon} , $V_{ref}(0x3FF, \text{min. value})$ (cf. *Electrical Characteristics No. 304*) and $R_{mda}(RMD(7:0) = 0x00, \text{max. value})$ (cf. *Electrical Characteristics No. 201*) are used. The following formula is used to calculate $R_{mda}(RMD(7:0) = 0x00, \text{max. value})$:

$$I_{mon}(max) = \frac{V_{ref}(0x3FF, \text{min})}{n \times R_{mda}(RMD = 0x00, \text{max})} = \frac{1.00}{280} = 3.5 \text{ mA}$$

n = 2 for EPNNP = 1
n = 1 for EPNNP = 0

Any other I_{mon} value can be calculated using the Rmd formula above. Due to its logarithmic characteristic, the steps between two consecutive values is kept typically within 3.3% of the nominal value. This formula provide only an approximated value of the resistor. Because of the coupling factor between laser and photodiode and

iC-HTG POWER CW LASER DIODE DRIVER

Rev B1, Page 16/40

the parametric variation of the PLR, each system has to be calibrated separately.

iC-HTG is optimized for driving P-type and N-type laser diodes. Figure 5 shows two examples of driving P-type and N-type laser diodes using APC mode. More examples of possible configurations on page 34.

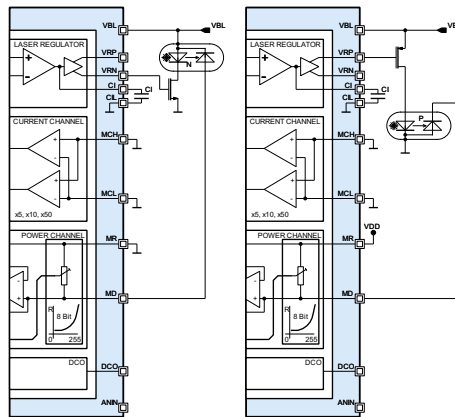

Figure 5: APC with N-channel and P-channel output transistor using N-type and P-type laser diodes. EACC = 0, MCVR = 0, EPNNP = 0 for N-type lasers or EPNNP = 1 for P-type lasers

APC mode monitoring the laser current

In APC mode, there is the possibility to monitor the laser current using the 10-bit linear A/D converter and/or to use the overcurrent monitor function. More about overcurrent on page 17. To measure the optical power, a shunt resistor must be connected to pins MCH/MCL and the register ADCC(2:0) has to be set to 0b100.

ADCC(2:0)	Addr. 0x10; bit 7:5	R/W 000
Code	Function	
000	ADC sourced by $V(VDD) \div 8$ (3 .. 5.5 V)	
001	ADC sourced by $V(VBL) \div 30$ (3 .. 24 V)	
010	ADC sourced by $V(VB) \div 30$ (3 .. 24 V)	
011	ADC sourced by $V(MDL)$ (0 .. 1.1 V)	
100	ADC sourced by $V(MC)$ (0 .. 1.1 V)	
101	ADC sourced by $V(VRN) \div 30$ (0 .. 24 V)	
110	ADC sourced by $V(VRP) \div 30$ (0 .. 24 V)	
111	ADC sourced by $V(ANIN)$ (0 .. 1.1 V)	

Table 16: ADC source selection

Thus, the internal voltage $MC = V(MCH) - V(MCL)$ will be selected as an input for the 10-bit A/D converter.

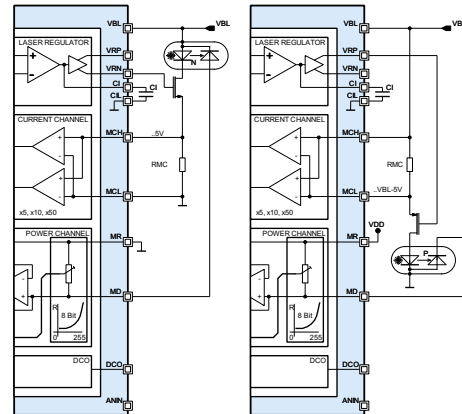

Figure 6: Example of APC monitoring the laser current. EACC = 0. Left: MCVR = 0, EPNNP = 0. Right: MCVR = 1, EPNNP = 1

More configuration examples on page 34.

Other functions

For some special applications (for example with low VB/VBL) it is useful to drive VRN up to VBL. In this case, the register bit VRNHR has to be set to '1'. The default and recommended value is setting the register bit VRNHR to '0'.

VRNHR	Addr. 0x13; bit 4	R/W 0
Code	Function	
0	VRN set from 0V to VBL-1V	
1	VRN set from 1V to VBL	

Table 17: VRN voltage range

Some applications might need an extra amplification stage after VRN/VRP with inversion of the polarity of the control. For such application, the register bit NSW is to be set to '0' and the polarity of the controller inverted.

NSW	Addr. 0x13; bit 6	R/W 1
Code	Function	
0	Inverted control mode (reference connected to negative input of regulator)	
1	Standard control mode (reference connected to positive input of regulator)	

Table 18: CI regulator reference swap

IC-HTG POWER CW LASER DIODE DRIVER

Rev B1, Page 17/40

OVERCURRENT MONITOR

A programmable overcurrent shutdown can be set to protect the laser by disabling the channel. If the voltage drop at the external shunt resistor $V(MCH) - V(MCL)$ is higher than the programmed value the overcurrent signal, OVC, is set and the laser channel is disabled. The maximum voltage drop at the shunt resistor can be programmed using the register ILIM(7:0).

ILIM(7:0)		Addr. 0x11; bit 7:0	R/W 0x00
Code	Function		
0x00	Overcurrent detection disconnected.		
0x01	Minimum value of $V(MCH)-V(MCL)$ set to minimum value typ. (0.1V/CGAIN)		
...			
0xFF	Maximum value of $V(MCH)-V(MCL)$ set to maximum value typ. (1.1V/CGAIN)		

Table 19: ILIM overcurrent register

An overcurrent event can be simulated using SOVC. If $SOVC = 1$ and the overcurrent detection is enabled (ILIM not set to 0x00), the corresponding overcurrent error bit OVC is set to 1, the error is signaled at NCHK, and the laser channel is disabled. The overcurrent error will remain forced until $SOVC = 0$.

SOVC		Addr. 0x16; bit 5	R/W 0
Code	Function		
0	No overcurrent event is simulated.		
1	Overcurrent event simulated.		

Table 20: Simulate overcurrent

WATCHDOG TIMER

The internal 200 kHz oscillator is monitored with a watchdog timer (WDT).

If the oscillator remains longer than the maximum time of tWDT (cf. *Electrical Characteristics No. E03*) without activity, an oscillator error is triggered. An oscillator error sets OSCERR error bit to '1'. The automatic off-set compensation of the laser control (see page 13) requires the oscillator.

The state of OSCERR is signaled at pin NCHK. The signaling of OSCERR state can be masked with bit MOSCERR. Setting MOSCERR to '1' masks the oscillator error and in this case OSCERR is not signaled at NCHK.

It is possible to simulate an error of the oscillator using bit SOSCERR. If $SOSCERR = 1$, the oscillator error is forced. When OSCERR is set to '1', the error is signaled through NCHK depending on the state of MOSCERR.

OSCERR		Addr. 0x00; bit 6	R
Code	Function		
0	Oscillator functioning OK		
1	Watchdog timeout set on oscillator failure. Cleared on read		

Table 21: Oscillator watchdog

MOSCERR		Addr. 0x16; bit 0	R/W 0
Code	Function		
0	Oscillator error (watchdog) will be signaled at NCHK		
1	Oscillator error (watchdog) will not be signaled at NCHK		

Table 22: Oscillator watchdog error mask

SOSCERR		Addr. 0x16; bit 7	R/W 0
Code	Function		
0	No oscillator error simulated.		
1	Oscillator error simulated (watchdog timeout).		

Table 23: Simulate oscillator error

iC-HTG POWER CW LASER DIODE DRIVER

Rev B1, Page 18/40

SERIAL COMMUNICATION INTERFACES

Communication modes

iC-HTG can be configured via a serial interface. It has two communication modes: SPI and I²C. Selection of the communication protocol is achieved using pin INS: INS = hi for I²C, INS = lo for SPI. If the pin INS is left open, NCHK will be pulled to 0.

SPI slave interface

The SPI slave interface is enabled by setting pin INS to lo and the interface uses pins NCS/A1, SCLK/SCL, MISO/SDA and MOSI/A0. The pin NCS/A1 is the chip select pin and must be set lo by the SPI master in order to start communication. The pins MISO/SDA and MOSI/A0 are the data communication lines and pin SCLK/SCL is the clock line generated by the SPI mas-

ter (e.g. a microcontroller). The SPI protocol frames are shown in Figure 7.

A communication frame consists of one address byte and at least one data byte. The bits 7:6 of the address byte are the opcode used for selecting a read operation (set to "10") or a write (set to "01") operation. The remaining 6 bits are used for register addressing.

It is possible to transmit several bytes consecutively if the NCS signal is not reset and SCLK/SCL keeps clocking, as is shown in Figure 7. The address is internally incremented after each transmitted byte. Once the address reaches the last register (0x3F), it is reset back to 0x00.

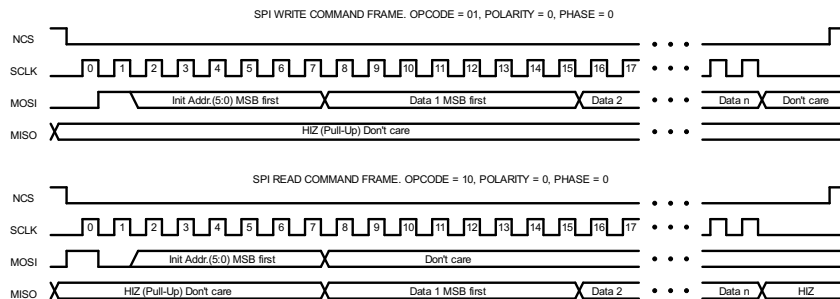

Figure 7: SPI commands

Action	b7	b6	b5	b4	b3	b2	b1	b0
Write to slave	1	0	1	0	ID	A1	A0	0
Read from slave	1	0	1	0	ID	A1	A0	1

Table 24: I²C write/read byte

I²C slave interface

The I²C slave interface is enabled by setting pin INS to hi and the interface uses pins NCS/A1, SCLK/SCL, MISO/SDA, ID, and MOSI/A0. The protocol frames are shown in Figure 8.

A communication frame consists of one slave address byte, one register address byte, and at least one data byte. The bits 7:1 of the slave address byte are build from the slave identification code (ID) and the address bit A1 and A0. Bit 0 is used to specify the data direction (RNW: 1 for read, 0 for write).

The four most significant bits are fixed by default to the value 0b1010. Pins MOSI/A0, NCS/A1, and ID are

used to set the remaining slave ID bits (see Tables 24 and 25).

Action	ID	A1	A0	Slave ID	Command byte
Write to slave 0	lo	lo	lo	0x50	0xA0
Read from slave 0	lo	lo	lo	0x50	0xA1
Write to slave 1	lo	lo	hi	0x51	0xA2
Read from slave 1	lo	lo	hi	0x51	0xA3
Write to slave 2	lo	hi	lo	0x52	0xA4
Read from slave 2	lo	hi	lo	0x52	0xA5
Write to slave 3	lo	hi	hi	0x53	0xA6
Read from slave 3	lo	hi	hi	0x53	0xA7
Write to slave 4	hi	lo	lo	0x54	0xA8
Read from slave 4	hi	lo	lo	0x54	0xA9
Write to slave 5	hi	lo	hi	0x55	0xAA
Read from slave 5	hi	lo	hi	0x55	0xAB
Write to slave 6	hi	hi	lo	0x56	0xAC
Read from slave 6	hi	hi	lo	0x56	0xAD
Write to slave 7	hi	hi	hi	0x57	0xAE
Read from slave 7	hi	hi	hi	0x57	0xAF

Table 25: I²C write/read command byte

IC-HTG POWER CW LASER DIODE DRIVER

Rev B1, Page 19/40

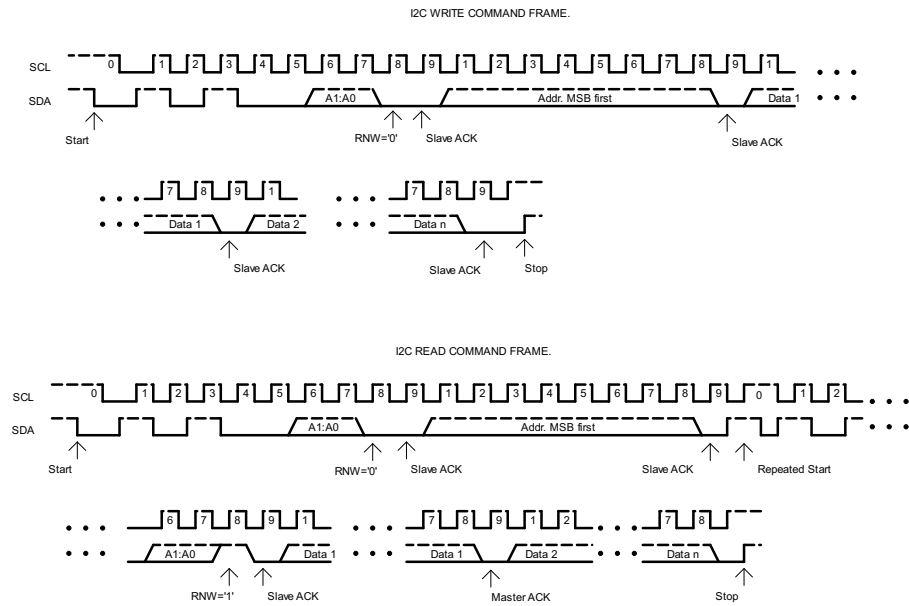

Figure 8: I²C commands

8-BIT INTERNAL PROGRAMMABLE LOGARITHMIC MONITOR RESISTORS

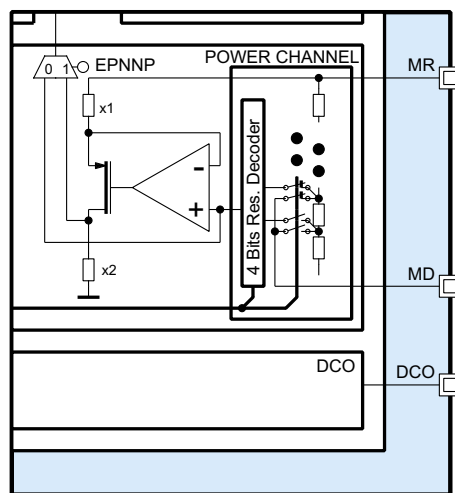

Figure 9: PLR internal node control

An internal 8-bit programmable logarithmic monitor resistor (PLR) is provided for the APC.

The PLR is used to control the optical power of the laser diode in APC mode or to measure a monitor photocurrent in ACC mode using the internal A/D converter. The resistor is connected to pins MR and MD using a force & sense switch structure. This ensures a low thermal dependency and a monotone dependence on the resistor with the register value RMD(7:0). Direct measuring of the internal resistor at pins MD/MR is not possible (see Figure 9).

RMD(7:0)	Addr. 0x12; bit 7:0	R/W 0xFF
Code	Function	
0x00	PLR set to the minimum resistance	
...	PLR set to	
	$Rmd = Rmd_0(1 + \frac{\Delta Rmd(\%)}{100})^{n+1}$, n from 0 to 255	
0xFF	PLR resistor set to the maximum resistance	

Table 26: MR-MD resistance selection

IC-HTG POWER CW LASER DIODE DRIVER

Rev B1, Page 20/40

The internal resistor value can be selected from 256 values, ranging from typ. $R_{md0} = 100 \Omega$ to over 407 k Ω , following logarithmic increments with a typical step width of $\Delta R_{md} = 3.3\%$. The resistors are configured with register RMD(7:0).

The following formula calculates the register RMD(7:0) in order to set the desired resistor value:

$$R_{md} = R_{md0} \left(1 + \frac{\Delta R_{md}(\%)}{100} \right)^{n+1}, \quad n \in [0, 255],$$

Where R_{md0} is the minimum resistor value (typically 100 Ω), $\Delta R_{md}(\%)$ is the step between two consecutive resistor values (typically 3.3%) and n is the decimal value of register RMD(7:0).

Since the PLR has parametric variations and covers a wide range of resistors values, the given formula is only for simulation or information purposes. Each system needs to be individually calibrated. The recommended procedure is to enable the channel with a high value of RMD(7:0) and a medium value on register REF(9:0). While measuring the optical power, the PLR value is re-

duced until the desired optical power is reached. Then using the register REF(9:0) you can make a more accurate selection of the optical power. For more information see page 13.

The PLR can be disabled via DISP.

DISP		Addr. 0x10; bit 2	R/W 0
Code	Function		
0	PLR enabled		
1	PLR disabled		

Table 27: Enable/disable PLR

In ACC mode the PLR is not part of the control circuit. Even though the PLR is not in the control circuit, it can be enabled (DISP = 0) in order to give feedback using the 10-bit A/D converter to monitor the optical power, if a monitor diode is connected.

Alternatively, an external monitor resistor can be used to measure the optical power, which requires DISP to be set to '1'.

10-BIT LOGARITHMIC D/A CONVERTER

The 10-bit logarithmic D/A converter is used for setting the regulator's voltage reference. The D/A converter is active in all operating modes. With a range from 0.1 to 1.1 V and the typical step width of $\Delta V_{ref} = 0.235\%$ (maximum $\Delta V_{ref} = 1\%$). This ensures that with each LSB step there is a maximum change of 1% of the optical power.

The D/A converter is configured by REF(9:0). With REF(9:0) = 0x000 the D/A output value is set to 0.1 V and with REF(9:0) = 0x3FF to 1.1 V.

REF(9:8)		Addr. 0x13; bit 1:0	R/W 0x000
REF(7:0)		Addr. 0x14; bit 7:0	R/W 0x000
Code	Function		
0x000	Regulator reference voltage set to minimum voltage		
...	Regulator reference voltage set to		
	$V_{ref} = V_{ref0} \left(1 + \frac{\Delta V_{ref}(\%)}{100} \right)^{n+1}$, n from 0 to 1023		
0x3FF	Regulator reference voltage set to maximum voltage		

Table 28: Channel regulator voltage reference

To calculate the D/A converter value for each REF(9:0) value, use the following equation.

$$V_{ref} = V_{ref0} \left(1 + \frac{\Delta V_{ref}(\%)}{100} \right)^{n+1}, \quad n \in [0, 1023]$$

Where V_{ref0} is the minimum value (typically 0.1 V), $\Delta V_{ref}(\%)$ is the step value (typically 0.235%) and n is the decimal value of register REF.

Since the D/A has parametric variations, the given formula is only for simulation or information purposes. Each system has to be individually calibrated. The recommended procedure in APC mode is to enable the channel with a high value of RMD(7:0) and a medium value of REF(9:0). While measuring the optical power, reduce the PLR value until the desired optical power is reached. Then, using REF(9:0), you can make a more accurate selection of the optical power.

For ACC mode it is recommended to enable the laser with an appropriate value of REF(9:0). While measuring the optical power, increase the value of REF(9:0), until the desired optical power is reached. For more information see page 13.

Linear mode

The reference voltage for the control can be chosen from a 10 bit logarithmic DAC or a 10 bit Linear DAC with the LINLOG register. In the linear mode (LINLOG = 1), if the ADC is enabled, some noise might be present, since the reference for the control will be sampled and held during the ADC conversion cycle.

IC-HTG POWER CW LASER DIODE DRIVER

Rev B1, Page 21/40

LINLOG		Addr. 0x16; bit bit 3	R/W 0
Code	Function		
0	Logarithmic 10 bit DAC selected		
1	Linear 10 bit DAC selected		

Table 29: Linear or Logarithmic reference selection

LINLOG	OVC
0	Normal function
1	Disabled

Table 30: Overcurrent detection in Linear/Logarithmic Mode

LINLOG also affects the overcurrent detection.

10-BIT LINEAR A/D CONVERTER

A 10-bit linear A/D converter is available for a variety of voltages that can be measured with different resolutions:

- V(VDD) up to 5.5 V with 8.6 mV resolution
- V(VBL) up to 30 V with 32.3 mV resolution
- V(VB) up to 30 V with 32.3 mV resolution
- V(MDL) internal voltage up to 1.1 V with 1.075 mV resolution
- V(MC) internal voltage up to 1.1 V with 1.075 mV resolution
- V(VRN) up to 30 V with 32.3 mV resolution
- V(VRP) up to 30 V with 32.3 mV resolution
- V(ANIN) up to 1.1 V with 1.075 mV resolution

As described in block diagram on Page 1, the voltages V(VDD), V(VBL), V(VB), V(VRN), V(VRP) and V(ANIN) are the PIN Voltage directly. V(MC) is proportional to the laser current value and is the voltage difference between pins MCH and MCL ($V(MC) = V(MCH) - V(MCL)$). The voltage V(MDL) is proportional to the optical laser power (monitor current) and the value is the absolute value of the difference between the pins MD and MR ($V(MDL) = |V(MD) - V(MR)|$).

The register ADCC(2:0) select the signal measured with the 10-bit A/D converter.

ADCC(2:0)		Addr. 0x10; bit 7:5	R/W 000
Code	Function		
000	ADC sourced by V(VDD) ÷ 8 (3 .. 5.5 V)		
001	ADC sourced by V(VBL) ÷ 30 (3 .. 24 V)		
010	ADC sourced by V(VB) ÷ 30 (3 .. 24 V)		
011	ADC sourced by V(MDL) (0 .. 1.1 V)		
100	ADC sourced by V(MC) (0 .. 1.1 V)		
101	ADC sourced by V(VRN) ÷ 30 (0 .. 24 V)		
110	ADC sourced by V(VRP) ÷ 30 (0 .. 24 V)		
111	ADC sourced by V(ANIN) (0 .. 1.1 V)		

Table 31: ADC source selection

DRDY		Addr. 0x07; bit bit 0	R
Code	Function		
0	No new ADC data since last read		
1	New ADC data available		

Table 32: ADC data ready

ENADCDIV		Addr. 0x16; bit bit 2	R/W 1
Code	Function		
0	ADC input voltage dividers disabled		
1	ADC input voltage dividers enabled		

Table 33: ADC voltage dividers enable

When enabled, the A/D converter is continuously acquiring the signal selected by register ADCC. The conversion time is 140 µs. Changing the source with ADCC may require up to 500 µs settling time of the sampling capacitors. Every time a conversion is finished, the bit DRDY is set. The MCU can poll the DRDY register and when a conversion is ready, read the correspondent data registers. The DRDY registers are clear when read and set back to one after a new conversion is ready.

Sampling input signals at a certain moment

To perform a conversion of an input signal at a certain moment (sampling), procedure can be as follows:

1. Enable the input voltage dividers (ENADCDIV = 1). Set ADCC to the desired input source and wait for the settling time (up to 500 µs).
2. Disable ADC (ENAD = 0). This will cause DRDY to be cleared.
3. Enable ADC at the desired measurement moment to hold the input signal (ENAD = 1).
4. Poll DRDY register until set to one and read ADC data.
5. Repeat from 2.

As the A/D converter is 10 bit long, the results are split into two byte wide separated registers; ADCh contains channel x ADC MSBs values while ADCl stores the LSBs. The A/D converter must be stopped before the

iC-HTG POWER CW LASER DIODE DRIVER

Rev B1, Page 22/40

result can be read to prevent measurement change during MSB and LSB readout. The procedure is as follows:

1. Enable if not already the input voltage dividers (ENADCDIV set to 1), set ADCC to the desired input source with the ADC disabled (ENAD set to 0) and wait for the settling time (Item. 701, up to 500us)
2. Start ADC conversion (ENAD set to 1).
3. Wait for DRDY set to 1.
4. Stop the ADC (ENAD set to 0).
5. Read the ADC data.
6. If ADC input source doesn't need to be changed, repeat from 2.

If the ADC converter is not to be used, the input voltage dividers can be disconnected to save some current (ENADCDIV set to 0).

The voltage corresponding to the measured digital value can be directly obtained using the following formula:

$$V(VBL, VB, VRP, VRN) = 30 * \frac{VFS}{1024} * ADCx$$

$$V(VDD) = 8 * \frac{VFS}{1024} * ADCx$$

$$V(MDL, MC, ANIN) = \frac{VFS}{1024} * ADCx$$

VFS is the full scale voltage of the A/D converter (cf. *Electrical Characteristics No. 706*) typically 1.1 V. For a more precise measurement the A/D converter can be calibrated by measuring a known VB voltage and calculating the VFS.

ADC(9:8)	Addr. 0x03; bit 1:0	R
ADC(7:0)	Addr. 0x04; bit 7:0	R
0x000	ADC minimum value	
...		
0x3FF	ADC maximum value	

Table 34: ADC

ANIN GENERAL PURPOSE IO PIN

The Pin ANIN is a general purpose IO Pin. Figure 10 describes the functionality of pin ANIN.

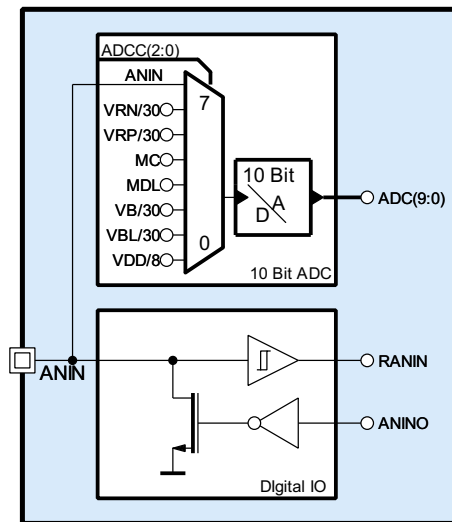

Figure 10: ANIN pin function description

With the pin ANIN an external analog voltage from 0 to 1.1 V can be digitized using the 10 bit linear A/D con-

verter. To this end register bit ANINO has to be set to 1 and the register ADCC(2:0) has to be set to value 0x07. For the digitizing higher voltages a resistor divider is recommended. An example of measuring voltages up to 24 V is shown in Figure 13.

ANIN can be used as a digital open collector output. As digital output an external pull-up resistor needs to be used. The maximum allowed voltage at pin ANIN is 5 V. With register bit ANINO the state of ANIN will be set.

ANINO	Addr. 0x1C; bit 2	R/W 1
Code	Function	
0	ANIN pin pulled low (open collector)	
1	ANIN pin set to high impedance	

Table 35: ANIN output state

RANIN	Addr. 0x01; bit 4	R
Code	Function	
0	ANIN pin is digital low at the precise reading moment.	
1	ANIN pin is digital high at the precise reading moment.	

Table 36: ANIN pin state

As digital TTL input the pin ANIN is mapped to status register bit RANIN.

iC-HTG POWER CW LASER DIODE DRIVER

Rev B1, Page 23/40

DC/DC CONVERTER OPTIMIZATION

iC-HTG provides a 6-bit configurable current source at pin DCO that can be used to trim the output voltage of a DC/DC converter. Current at DCO can be programmed with register RDCO(5:0). In standby mode, DCO current source is disconnected and set to high impedance. Possible application benefits with using DCO include:

- DC/DC step down operation: control at voltages lower than power supply
- DC/DC step up operation: control at voltages higher than power supply
- Efficiency enhancement

RDCO(5:0)		Addr. 0x15; bit 5:0	R/W 0x00
Code	Function		
0x00	No current		
...			
0x3F	130 µA Typ (see spec point D01)		

Table 37: DCO current control

The proposed applications can be demonstrated with a standard DC/DC converter, e.g. TPS63060DSC from Texas Instruments. This converter allows an input voltage ranging from 2.5 to 12 V and offers an output voltage ranging from 2.5 to 8 V. It is capable of delivering up to 2 A of current, depending on the output voltage. Figure 11 shows a possible configuration.

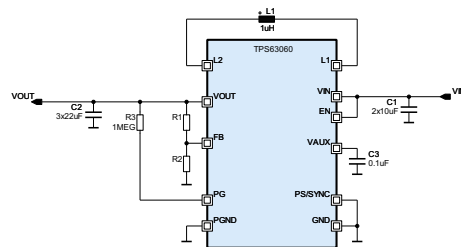

Figure 11: TPS63060 DC/DC converter from TI

DC/DC step down operation: control at voltages lower than power supply

The resistors R1 and R2 in the feedback path allow setting the desired output value Vout. The DC/DC converter drives Vout pin in order to yield 0.5 V at feedback pin FB. The DCO output signal from iC-HTG is connected to pin FB. Vout is controlled with the internal register RDCO(5:0) from iC-HTG.

The DCO current into FB controls the voltages of the divider R1 and R2 and Vout changes in order to maintain

0.5 V at the pin FB. When selecting R1 and R2, one needs to consider:

- Resistors values: $R1 = R2 \left(\frac{V_{out}}{V_{FB}} - 1 \right)$
- The current of the voltage divider should be high enough in comparison to the current from the pin DCO to offer acceptable resolution. The programmable current resolution of register RDCO(5:0) is 2 µA.
- The DCO current into the voltage divider lowers the voltage Vout. Vout is 8 V when no current is present at DCO.

Choosing R1 = 100 kΩ, the value of R2 can be calculated to:

$$R2 = \frac{R1}{\frac{V_{out}}{V_{FB}} - 1} = \frac{100k}{\frac{8V}{0.5V} - 1} = 6.7 k\Omega$$

With this configuration, the current through the voltage divider is 75 µA at 8 V. The resolution of each RDCO(5:0) step is then 200 mV.

The value in RDCO(5:0) register needed in order to have the desired output voltage can be calculated using the following formula:

$$RDCO = \frac{I_{dco}}{2 \mu A} = \frac{IR2 - IR1}{2 \mu A} = \frac{0.5V}{8.72} \frac{V_{out} - 0.5V}{2 \mu A}$$

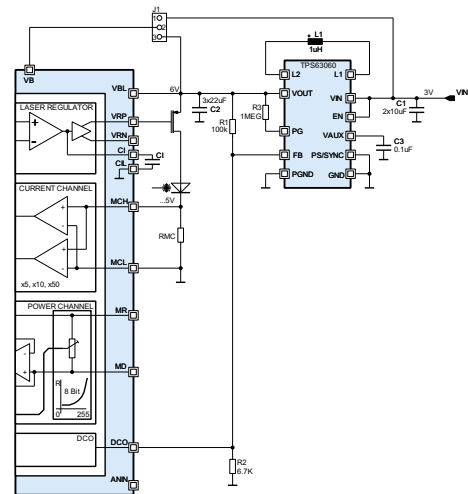

Figure 12: Control of VB/VBL Supply using DCO

The resulting value varies slightly depending on the tolerances of the selected resistors and the DCO current. iC-HTG incorporates an internal 10-bit A/D converter.

iC-HTG POWER CW LASER DIODE DRIVER

Rev B1, Page 24/40

Selecting VBL or VB as input of this converter the supply voltage can be measured and the selected current at DCO can be changed in order to obtain the desired voltage at VBL/VB. Setting register ADCC(2:0) to 0b001 or 0b010, the supply voltages VBL or VB can be measured, respectively. The digitized value is the supply value divided by 30.

DC/DC step up operation: control at voltages higher than power supply

A practical application of the present case is the control of blue lasers. This type of laser presents a forward voltage around 5V, which demands a voltage of about 6V for the anode of the laser diode (LDA). If the system is supplied from a 3V LiPo battery, it is necessary to use a DC/DC in order to step up and drive the laser diode and driver with a sufficient voltage. Figure 12 shows this application. Jumper J1 can be set to 1-2 or 2-3 position.

Typically setting register RDCO(5:0) to 10 it delivers 20 μ A and 6V, which are obtained at Vout.

Extension of system working voltage range

iC-HTG may be supplied with a voltage within the threshold values of 3 and 24V. It is possible to control the DC/DC output in a voltage range of 2.5 to 24V, if the DC/DC converter controlled by the DCO output signal is included in the system, as it is shown in Figure 12.

In Figure 12 both the laser and iC-HTG are supplied with output voltage Vout from DC/DC converter. Typically the register RDCO(5:0) is set to 23, which forces 48 μ A to be output to the voltage divider. A system voltage of 3.3V is obtained at Vout.

Efficiency enhancement

If iC-HTG and the laser diode are supplied with the same power supply, the efficiency of the driver can be improved depending on the supplied voltage, the saturation voltage, and the laser diode forward voltage. The power dissipation of the driver transistor can be reduced if VBL is set through the DC/DC converter configured to deliver a voltage lower than the power supply as shown in Figure 13.

For this application the pin ANIN must be configured as an input by setting the register bit ANINO to 1. Using the resistors RA1 and RA2, the drain voltage at the

drive transistor is reduced by a factor of approximately 30. For more information about ANIN see page 22.

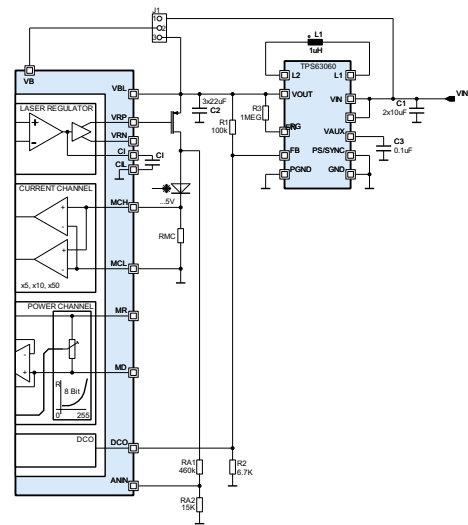

Figure 13: System efficiency enhancement

ANINO	Addr. 0x1C; bit 2	R/W 1
Code	Function	
0	ANIN pin pulled low (open collector)	
1	ANIN pin set to high impedance	

Table 38: ANIN output state

In this configuration, the voltage drop at the driver transistor can be measured and minimized by setting an appropriate supply at VBL. Some steps have to be done to optimize the power dissipation:

1. Measure the voltage at pin VBL, setting the register ADCC(2:0) to 0b001. The measured voltage AD(VBL) is divided by a factor of 30.
2. Measure the voltage at pin ANIN, AD(ANIN).
3. The voltage drop at the driver transistor is $(AD(VBL) - AD(ANIN)) * 30$. By changing the DCO(6:0) register, the supply voltage at V(VBL) can be increased or decreased. ANIN should remain constant.
4. Repeat steps 1 to 3 to achieve the desired voltage drop at the output transistor.

iC-HTG POWER CW LASER DIODE DRIVER

Rev B1, Page 26/40

$$(2) I(RMC) = \frac{V_{MOD}}{1023} \cdot \frac{REFx}{CGAINx} \cdot \frac{1}{RMC}$$

With this equation the theoretical current value can be calculated. More accurate calculations can be made using the parameters 303 304 and 305 of the Electrical Characteristics and the equation (3) and (4).

$$(3) V(RMC) = \frac{V_{MOD}}{1.1} \cdot \frac{V(REF)}{G(1)}$$

$$(4) I(RMC) = \frac{V_{MOD}}{1.1} \cdot \frac{V(REF)}{G(1)} \cdot \frac{1}{RMC}$$

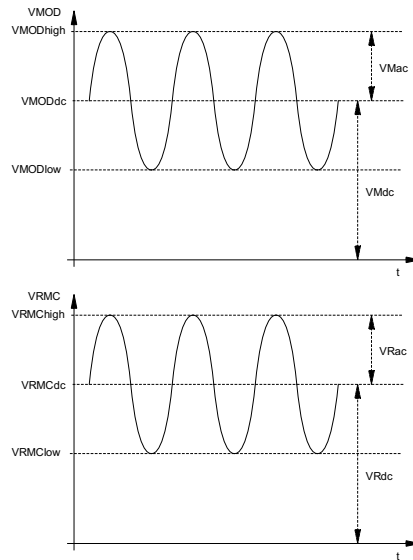

Figure 17: Example of modulation voltages

Due to the parameter variation is recommended to calibrate each circuit. The recommended procedure to set the current modulation values is:

1. Set the GAINx(1:0) value (0x00 is recommended).
2. Set a reference value of voltage in V(MOD). For example a low voltage or a DC voltage (VMODdc) in a sinus signal as shown in figure 17.
3. With a fixed voltage at V(MOD) (for example VMODdc) use REF(9:0) to set the desired

V(RMC) (in this case V(RMCdc) for current laser I(RMCdc)). You can use the internal AD-Converter to sense the voltage at RMC.

Note that using the equation the laser current I(RMCdc) is:

$$(5) I(RMCdc) = \frac{V_{MODdc}}{1.1} \cdot \frac{V(REF)}{G(1)} \cdot \frac{1}{RMC}$$

4. With this setup the relationship between the voltage at V(MOD) and the referenced current is given by (7):

$$(6) I(RMChigh) = \frac{V_{MODhigh}}{1.1} \cdot \frac{V(REF)}{G(1)} \cdot \frac{1}{RMC}$$

$$(7) \frac{I(RMChigh)}{I(RMCdc)} = \frac{V_{MODhigh}}{V_{MODdc}}$$

Analog Modulation in APC mode

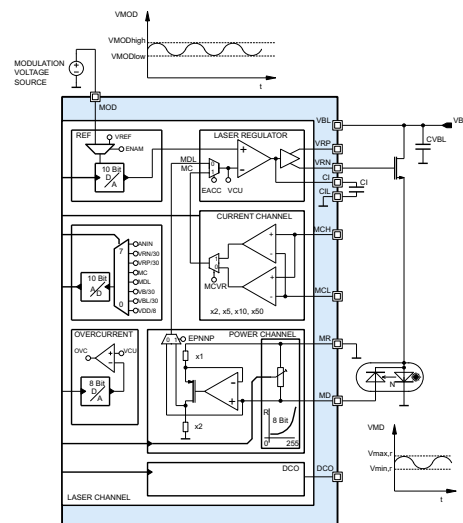

Figure 18: Example of Analog Modulation using APC mode

It is possible to use analog modulation using an APC mode. In this case the stability of the system is more critical and higher CI capacitors (> 1 nF) are recommended. This is depending on laser diode, PCB and logarithmic resistor setting. Only a few kHz are recommended for the analog modulation in APC mode. An example of configuration using analog modulation in APC mode is shown in Figure 18.

iC-HTG POWER CW LASER DIODE DRIVER

Rev B1, Page 27/40

TEMPERATURE MONITOR AND PROTECTION

iC-HTG includes an 8-bit temperature monitor that allows to measure the internal chip temperature going from -40 to 125 °C. The resolution is 1 °C/LSB.

TEMP(7:0)		Addr. 0x02; bit 7:0	R
Code	Function		
0x00	Minimum temperature		
...			
0xFF	Maximum temperature		

Table 40: Chip temperature

Absolute read values may differ from one chip to another. An individual initial calibration of the temperature monitor is recommended. The TEMP register must be read at a known temperature. Using the resolution value of 1 °C/LSB, the internal temperature can be calculated.

The temperature monitor can be used to compensate temperature effects in the laser diode. The microcontroller can use a laser diode characteristic formula or a look-up table combined with the temperature value measured using TEMP register. The reference voltage can be configured accordingly in order to compensate for temperature effects.

iC-HTG is protected against overtemperature. If the internal temperature exceeds a safe value, an overtem-

perature error bit (OVT) is set to 1. If OVT = 1, the laser channel is disabled and the error event is signaled through pin NCHK. The error bit OVT is latched and can only be cleared by reading the status register.

The overtemperature threshold value can not be configured.

OVT		Addr. 0x00; bit 3	R
Code	Function		
0	No overtemperature event has occurred since last read		
1	Overtemperature event has occurred. Cleared on read		

Table 41: Overtemperature

It is possible to simulate an overtemperature event using the bit SOVT. Setting SOVT to 1, the overtemperature error flag OVT is set to 1. iC-HTG remains in the error state until SOVT is set back to 0.

SOVT		Addr. 0x16; bit 4	R/W 0
Code	Function		
0	No overtemperature event is simulated.		
1	Overtemperature event simulated.		

Table 42: Simulate overtemperature

CONFIGURATION MODE AND MEMORY INTEGRITY MONITOR

iC-HTG supports the interfaces SPI or I²C, which are selected by the INS pin. More information about the serial communication interface on page 18.

In the configuration mode the iC-HTG configuration can be amended without affecting the configuration stored in the iC-HTG RAM. Only when switching back to the operation mode, the configuration is applied to the iC-HTG in an atomic operation (all at once).

Integrity monitoring is implemented by a duplication of the configuration registers into a validation page (see description below) where the registers are automatically copied with their inverted values. Every register bit is compared with its validation copy and, in case of inconsistency, a memory error is generated and the laser channel is switched off.

Atomic appliance is achieved by latching the configuration registers. This permits a full configuration (different

registers) to be made prior to applying it to the laser channel.

The configuration mode is selected by setting the register MODE(1:0) to 10.

MODE(1:0)		Addr. 0x1C; bit 1:0	R/W 01
Code	Function		
00	Not allowed, signaled as memory error		
01	Chip set in operation mode (apply configuration, latch transparent)		
10	Chip set in configuration mode (hold previous configuration)		
11	Not allowed, signaled as memory error		

Table 43: Select configuration or operation mode

In **Configuration mode** the *configuration memory* (addr. 0x10 to 0x1F) can be written and read back to check a correct communication without changing the

iC-HTG POWER CW LASER DIODE DRIVER

Rev B1, Page 28/40

present configured operation state of the iC-HTG. In this mode, the memory integrity check is disabled.

iC-HTG will monitor the time elapsed in configuration mode and automatically switch the laser off, if it exceeds a configuration mode timeout. The time in configuration mode must be less than 40 ms to ensure that no configuration timeout occurs during configuration (cf. *Electrical Characteristics No. E02*).

When writing the configuration is completed, iC-HTG is switched to **operating mode** by writing "01" into the MODE register (addr. 0x1C). In **operating mode** the configuration is applied to the iC-HTG and the memory integrity check activated. In this mode configuration registers can only be read (except MODE(1:0) register, which is always accessible). Figure 19 shows the interface to the memory structure.

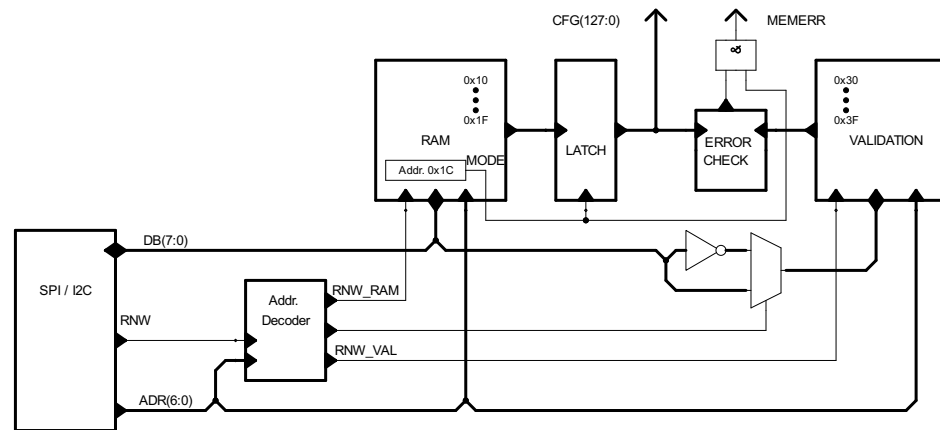

Figure 19: Interface, RAM integrity monitoring, and configuration latching

Register map description

The register map consists of 64 addresses subdivided in three different pages:

- Read-only page, addr. 0x00 to 0x0F: iC-HTG status, ADC readout, temperature sensor readout and chip revision
- Configuration page (integrity monitored), read/write registers, addr. 0x10 to 0x1F
- Validation page, read/write registers, addr. 0x30 to 0x3F

Read-only registers with values or states

The read-only registers are sub-divided into status registers (addr. 0x00 to 0x01) and measurement registers and the chip revision register CHIPREV. Status registers are normally latched to 1 on events and cleared on read (see individual register description). Measurement registers are dual-port and can be accessed simultaneously with the measurements in progress. ADC (addr. 0x03 to 0x04) is a 10-bit register split into two 8-bit registers and must be accessed in block mode (automatic address increment) to ensure data does not change during the read.

Configuration page (integrity monitored)

The configuration page (addr. 0x10 to 0x1F) contains the registers that control the driver. Every write operation to any of the registers of this page will be internally duplicated to the correspondent register at the validation page. After the write operation, the correspondent validation register contains the inverted value of the configuration register.

Validation page

The validation page (addr. 0x30 to 0x3F) can be read or written normally. Only when a write procedure is made to any of the configuration registers, the correspondent validation pair will be written with the inverted value of the configuration register as well.

Both the configuration and validation pages are initialized during power-up. This event is signaled at the STATUS0 register (bit 0, INITRAM). In standby mode (NSTBY = 1) the RAM is not reset if any write command has been executed and therefore configuration and validation pages keep the stored information and INITRAM remains unset. Entering standby mode after power-up without any write command, the RAM will be initialized again and the INITRAM bit will be set to 1

iC-HTG POWER CW LASER DIODE DRIVER

Rev B1, Page 29/40

again. Any VDD power-down event signaled at the STATUS0 register outside the standby mode (NSTBY = hi) requires a RAM content check regardless of the state of the INITRAM bit to ensure data is not corrupted.

Possible start-up sequence:

- iC-HTG starts in operation mode with default configuration. INITRAM and PDOVDD error bits are set in STATUS0, DISC (addr. 0x10, bit 3) is set to 1.
- Write MODE(1:0) = "10" register (addr. 0x1C) to enable the configuration mode.
- Configure the laser channel.
- Read back to verify a correct data transfer.
- Set the DISC bit to 0.
- Read the status registers (addr. 0x00, 0x01) to detect possible errors and validate status. At any error: read again to ensure that the error is valid.
- Write MODE(1:0) = "01" register (addr. 0x1C) to apply the configuration and enable the memory integrity check.
- During operation: monitor the status registers, checking for errors. The pin NCHK signals any set status bit if not masked. This pin can be used to trigger an microcontroller interrupt line.

REGISTER OVERVIEW

OVERVIEW								
Addr	Bit 7	Bit 6	Bit 5	Bit 4	Bit 3	Bit 2	Bit 1	Bit 0
0x00 R	CFGTIMO	OSCERR	OVC	PDOVBL	OVT	MEMERR	PDOVDD	INITRAM
0x01 R	0	0	0	RANIN	NMCOK	EC	MONC	MAPC
0x02 R	TEMP(7:0)							
0x03 R					ADC(9:8)			
0x04 R	ADC(7:0)							
0x05 R	0	0	0	0	0	0	0	0
0x06 R	0	0	0	0	0	0	0	0
0x07 R	0	0	0	0	0	0	0	DRDY
0x08 R	Not implemented							
...	Not implemented							
0x0F R	CHIPREV							
0x10	ADCC(2:0)			1	DISC	DISP	ENAD	EACC
0x11	ILIM(7:0)							
0x12	RMD(7:0)							
0x13	EPNPNP	NSW	0	VRNHR	ENAM	MCVR	REF(9:8)	
0x14	REF(7:0)							
0x15	CGAIN(1:0)			RDCO(5:0)				
0x16	SOSCERR		SOVC	SOVT	LINLOG	ENADCDIV	MMONC	MOSCERR
0x17	Reserved							
0x18	Not implemented							
0x19	Not implemented							
0x1A	Not implemented							
0x1B	Not implemented							
0x1C	Not implemented					ANINO	MODE(1:0)	
0x1D	Not implemented							
0x1E	Reserved register. Set to zero							
0x1F	Reserved register(Factory test). Set to zero							
0x20	Not implemented							
...	Not implemented							

iC-HTG

POWER CW LASER DIODE DRIVER

Rev B1, Page 30/40

OVERVIEW								
Addr	Bit 7	Bit 6	Bit 5	Bit 4	Bit 3	Bit 2	Bit 1	Bit 0
0x30	Validation content for 0x10, inverted							
0x31	Validation content for 0x11, inverted							
...	...							
0x3F	Validation content for 0x1F, inverted							

Table 44: Register layout

PARAMETERS

Register	Address	Bits	Description
INITRAM	0x00	0	RAM initialized.
PDOVDD	0x00	1	Power-down event at VDD
MEMERR	0x00	2	RAM memory validation error
OVT	0x00	3	Overtemperature event
PDOVBL	0x00	4	Power-down event at VBL
OVC	0x00	5	Overcurrent
OSCERR	0x00	6	Oscillator error (watchdog set)
CFGTIMO	0x00	7	Configuration mode timeout event
MAPC	0x01	0	Channel state
MONC	0x01	1	Channel enabled at least once (latched)
EC	0x01	2	EC pin digital state
NMCOK	0x01	3	MCL, MCH voltage status
RANIN	0x01	4	ANIN pin digital state

Table 45: Status overview

Register	Address	Bits	Description
TEMP	0x02	7:0	Chip temperature measurement
ADCh	0x03	1:0	ADC 9:8 readout
ADCI	0x04	7:0	ADC 7:0 readout
DRDY	0x07	0	ADC data ready
CHIPREV	0x0F	7:0	Chip revision identification

Table 46: Measurement overview

Status

PDOVDD		Addr. 0x00; bit 1	R
Code	Function		
0	VDD power down not occurred since last read		
1	VDD power down event has occurred. Cleared on read		

Table 48: VDD power down

INITRAM		Addr. 0x00; bit 0	R
Code	Function		
0	RAM not initialized since last read		
1	RAM initialized. Cleared on read		

Table 47: RAM initialization

iC-HTG POWER CW LASER DIODE DRIVER

Rev B1, Page 31/40

MEMERR		Addr. 0x00; bit 2	R
Code	Function		
0	RAM has not been changed since last validation		
1	RAM has changed and has not been validated		

Table 49: Memory validation

OVT		Addr. 0x00; bit 3	R
Code	Function		
0	No overtemperature event has occurred since last read		
1	Overtemperature event has occurred. Cleared on read		

Table 50: Overtemperature

PDOVBL		Addr. 0x00; bit 4	R
Code	Function		
0	VBL power down not occurred since last read		
1	VBL power down event has occurred. Cleared on read		

Table 51: VBL power down

OVC		Addr. 0x00; bit 5	R
Code	Function		
0	No overcurrent event has occurred since last read		
1	Overcurrent event has occurred. Cleared on read		

Table 52: Overcurrent

OSCERR		Addr. 0x00; bit 6	R
Code	Function		
0	Oscillator functioning OK		
1	Watchdog timeout set on oscillator failure. Cleared on read		

Table 53: Oscillator watchdog

CFGTIMO		Addr. 0x00; bit 7	R
Code	Function		
0	iC-HTG not in <i>configuration mode</i> or <i>timeout</i> did not happened till now		
1	iC-HTG in <i>configuration mode</i> and <i>timeout</i> happened. Laser switched off.		

Table 54: Configuration timeout

MAPC		Addr. 0x01; bit 0	R
Code	Function		
0	Channel is off at the precise reading moment		
1	Channel is on at the precise reading moment		

Table 55: Channel state

MONC		Addr. 0x01; bit 1	R
Code	Function		
0	Channel has not been switched on since last read		
1	Channel has been switched on at least once. Cleared on read		

Table 56: Channel state history

EC		Addr. 0x01; bit 2	R
Code	Function		
0	EC pin is high at the precise reading moment.		
1	EC pin is low at the precise reading moment.		

Table 57: EC pin state

NMCOK		Addr. 0x01; bit 3	R
Code	Function		
0	MCH-MCL voltage is OK for the selected laser type.		
1	MCH-MCL voltage is not OK for the selected laser type.		

Table 58: MCH-MCL voltage status

RANIN		Addr. 0x01; bit 4	R
Code	Function		
0	ANIN pin is digital low at the precise reading moment.		
1	ANIN pin is digital high at the precise reading moment.		

Table 59: ANIN pin state

TEMP(7:0)		Addr. 0x02; bit 7:0	R
Code	Function		
0x00	Minimum temperature		
...			
0xFF	Maximum temperature		

Table 60: Chip temperature

DRDY		Addr. 0x07; bit bit 0	R
Code	Function		
0	No new ADC data since last read		
1	New ADC data available		

Table 61: ADC data ready

iC-HTG POWER CW LASER DIODE DRIVER

Rev B1, Page 32/40

CHIPREV		Addr. 0x0F; bit 7:0	R
Code	Function		
16	iC-HTG 0		
17	iC-HTG 1		
18	iC-HTG Z		
19	iC-HTG Z1		
20	iC-HTG Y		
21	iC-HTG Y1		
22	iC-HTG X		
23	iC-HTG W		
24	iC-HTG W1		

Table 62: Chip revision

Channel configuration registers

EACC		Addr. 0x10; bit 0	R/W 0
Code	Function		
0	APC mode enabled (laser power control)		
1	ACC mode enabled (laser current control)		

Table 63: Select APC or ACC

ENAD		Addr. 0x10; bit 1	R/W 0
Code	Function		
0	AD Converter disabled		
1	AD Converter enabled, source selected with ADCC		

Table 64: Enable ADC

DISP		Addr. 0x10; bit 2	R/W 0
Code	Function		
0	PLR enabled		
1	PLR disabled		

Table 65: Enable/disable PLR

DISC		Addr. 0x10; bit 3	R/W 1
Code	Function		
0	Channel can be enabled by pin EC		
1	Channel cannot be enabled by pin EC		

Table 66: Disable channel

ADCC(2:0)		Addr. 0x10; bit 7:5	R/W 000
Code	Function		
000	ADC sourced by $V(VDD) \div 8$ (3 .. 5.5 V)		
001	ADC sourced by $V(VBL) \div 30$ (3 .. 24 V)		
010	ADC sourced by $V(VB) \div 30$ (3 .. 24 V)		
011	ADC sourced by $V(MDL)$ (0 .. 1.1 V)		
100	ADC sourced by $V(MC)$ (0 .. 1.1 V)		
101	ADC sourced by $V(VRN) \div 30$ (0 .. 24 V)		
110	ADC sourced by $V(VRP) \div 30$ (0 .. 24 V)		
111	ADC sourced by $V(ANIN)$ (0 .. 1.1 V)		

Table 67: ADC source selection

ILIM(7:0)		Addr. 0x11; bit 7:0	R/W 0x00
Code	Function		
0x00	Overcurrent detection disconnected.		
0x01	Minimum value of $V(MCH)-V(MCL)$ set to minimum value typ. (0.1V/CGAIN)		
...			
0xFF	Maximum value of $V(MCH)-V(MCL)$ set to maximum value typ. (1.1V/CGAIN)		

Table 68: ILIM overcurrent register

RMD(7:0)		Addr. 0x12; bit 7:0	R/W 0xFF
Code	Function		
0x00	PLR set to the minimum resistance		
...	PLR set to		
	$Rmd = Rmd_0(1 + \frac{\Delta Rmd(\%)}{100})^{n+1}$, n from 0 to 255		
0xFF	PLR resistor set to the maximum resistance		

Table 69: MR-MD resistance selection

REF(9:8)		Addr. 0x13; bit 1:0	R/W 0x000
REF(7:0)		Addr. 0x14; bit 7:0	R/W 0x000
Code	Function		
0x000	Regulator reference voltage set to minimum voltage		
...	Regulator reference voltage set to		
	$Vref = Vref_0(1 + \frac{\Delta Vref(\%)}{100})^{n+1}$, n from 0 to 1023		
0x3FF	Regulator reference voltage set to maximum voltage		

Table 70: Channel regulator voltage reference

MCVR		Addr. 0x13; bit 2	R/W 0
Code	Function		
0	MCx Voltage Range is 0 to 5V		
1	MCx Voltage Range is VBL – 5V to VBL		

Table 71: MCx voltage range

ENAM		Addr. 0x13; bit 3	R/W 0
Code	Function		
0	Analog modulation disabled		
1	Analog modulation enabled		

Table 72: Enable analog modulation

IC-HTG POWER CW LASER DIODE DRIVER

Rev B1, Page 33/40

NSW		Addr. 0x13; bit 6	R/W 1
Code	Function		
0	Inverted control mode (reference connected to negative input of regulator)		
1	Standard control mode (reference connected to positive input of regulator)		

Table 73: CI regulator reference swap

EPNPP		Addr. 0x13; bit 7	R/W 0
Code	Function		
0	N-type laser		
1	P-type laser		

Table 74: Enable P- or N- type laser

RDCO(5:0)		Addr. 0x15; bit 5:0	R/W 0x00
Code	Function		
0x00	No current		
...			
0x3F	130 µA Typ (see spec point D01)		

Table 75: DCO current control

CGAIN(1:0)		Addr. 0x15; bit 7:6	R/W 00
Code	Function		
00	Amplification set to x2		
01	Amplification set to x5		
10	Amplification set to x10		
11	Amplification set to x50		

Table 76: MCx voltage drop amplification

MOSCERR		Addr. 0x16; bit 0	R/W 0
Code	Function		
0	Oscillator error (watchdog) will be signaled at NCHK		
1	Oscillator error (watchdog) will not be signaled at NCHK		

Table 77: Oscillator watchdog error mask

MMONC		Addr. 0x16; bit 1	R/W 1
Code	Function		
0	Enable Channel will be signaled at NCHK		
1	Enable Channel will not be signaled at NCHK		

Table 78: Enable Channel (ENCH) monitor mask

SOVT		Addr. 0x16; bit 4	R/W 0
Code	Function		
0	No overtemperature event is simulated.		
1	Overtemperature event simulated.		

Table 79: Simulate overtemperature

SOVC		Addr. 0x16; bit 5	R/W 0
Code	Function		
0	No overcurrent event is simulated.		
1	Overcurrent event simulated.		

Table 80: Simulate overcurrent

SOSCERR		Addr. 0x16; bit 7	R/W 0
Code	Function		
0	No oscillator error simulated.		
1	Oscillator error simulated (watchdog timeout).		

Table 81: Simulate oscillator error

ENADCDIV		Addr. 0x16; bit bit 2	R/W 1
Code	Function		
0	ADC input voltage dividers disabled		
1	ADC input voltage dividers enabled		

Table 82: ADC voltage dividers enable

LINLOG		Addr. 0x16; bit bit 3	R/W 0
Code	Function		
0	Logarithmic 10 bit DAC selected		
1	Linear 10 bit DAC selected		

Table 83: Linear or Logarithmic reference selection

MODE(1:0)		Addr. 0x1C; bit 1:0	R/W 01
Code	Function		
00	Not allowed, signaled as memory error		
01	Chip set in operation mode (apply configuration, latch transparent)		
10	Chip set in configuration mode (hold previous configuration)		
11	Not allowed, signaled as memory error		

Table 84: Select configuration or operation mode

ANINO		Addr. 0x1C; bit 2	R/W 1
Code	Function		
0	ANIN pin pulled low (open collector)		
1	ANIN pin set to high impedance		

Table 85: ANIN output state

VRNHR		Addr. 0x13; bit 4	R/W 0
Code	Function		
0	VRN set from 0V to VBL-1V		
1	VRN set from 1V to VBL		

Table 86: VRN voltage range

iC-HTG POWER CW LASER DIODE DRIVER

Rev B1, Page 34/40

EXAMPLES OF CONFIGURATION

ACC mode

Examples of ACC mode using P-channel transistor, Figures 20 and 21.

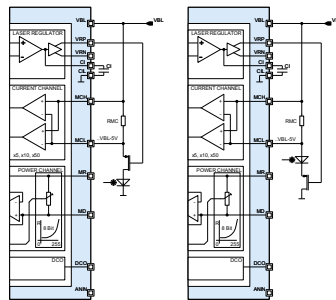

Figure 20: Working in ACC mode with P-channel output transistor as follower. **(Recommended)**

EACC	MCVR	EPNPP
1	1	-

Table 87: Register for Figure 20

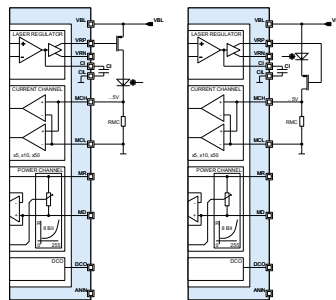

Figure 21: Working in ACC mode with P-channel output transistor

EACC	MCVR	EPNPP
1	0	-

Table 88: Register for Figure 21

Examples of ACC Mode using N-channel transistor, Figures 22 and 23.

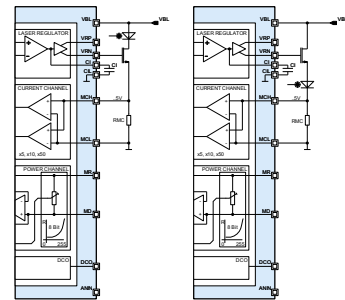

Figure 22: Working in ACC mode with N-channel output transistor as follower. **(Recommended)**

EACC	MCVR	EPNPP
1	0	-

Table 89: Register for Figure 22

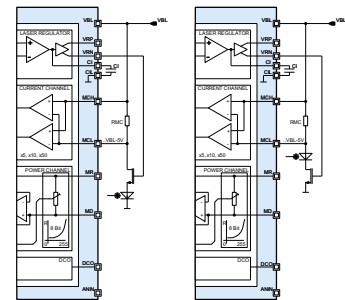

Figure 23: Working in ACC mode with N-channel output transistor.

EACC	MCVR	EPNPP
1	1	-

Table 90: Register for Figure 23

iC-HTG POWER CW LASER DIODE DRIVER

Rev B1, Page 35/40

APC mode

Examples of APC mode using N-channel transistor, Figures 24 and 25.

Examples of APC mode using P-channel transistor, Figures 26 and 27.

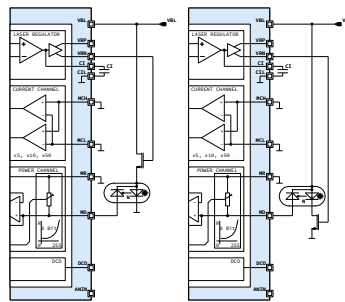

Figure 24: Working with N-channel output transistor and N-type laser diode.

EACC	MCVR	EPNPP
0	0	0

Table 91: Register for Figure 24

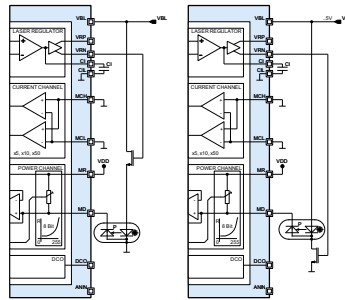

Figure 25: Working with N-channel output transistor and P-type laser diode.

EACC	MCVR	EPNPP
0	0	1

Table 92: Register for Figure 25

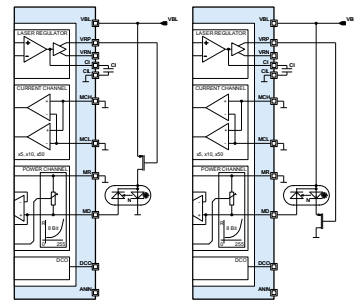

Figure 26: Working with P-channel output transistor and N-type laser diode.

EACC	MCVR	EPNPP
0	0	0

Table 93: Register for Figure 26

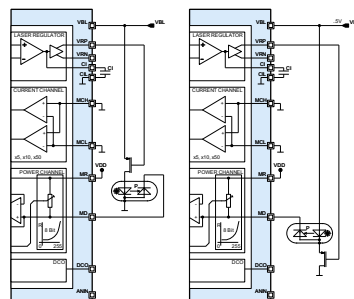

Figure 27: Working with P-channel output transistor and P-type laser diode.

EACC	MCVR	EPNPP
0	0	1

Table 94: Register for Figure 27

Note that in Figures 25 right and 27 right the VBL voltage is limited to 5 V.

iC-HTG POWER CW LASER DIODE DRIVER

Rev B1, Page 36/40

APC mode with current monitor or ACC mode with optical power monitor

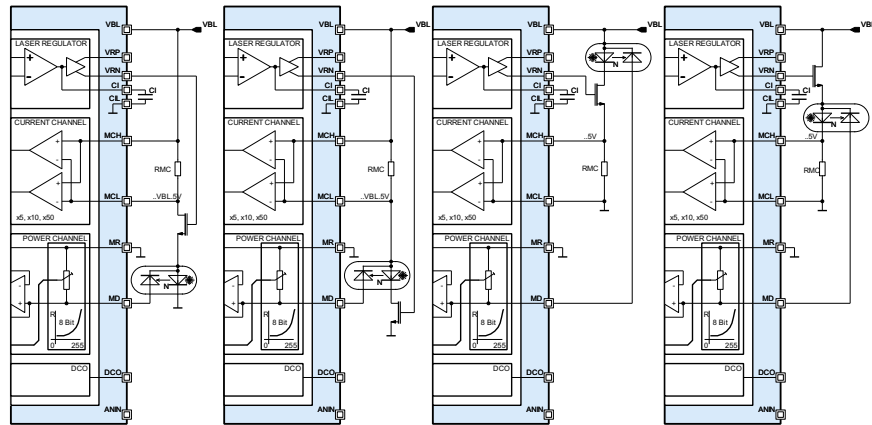

Figure 28: iC-HTG with N-channel output transistor and N-type laser diode.

Register	Figure 28.a	Figure 28.b	Figure 28.c	Figure 28.d	EACC	ADCC
MCVR	1	1	0	0	1	011
EPNNP	0	0	0	0	0	100

Table 95: Configuration register for Figure 28

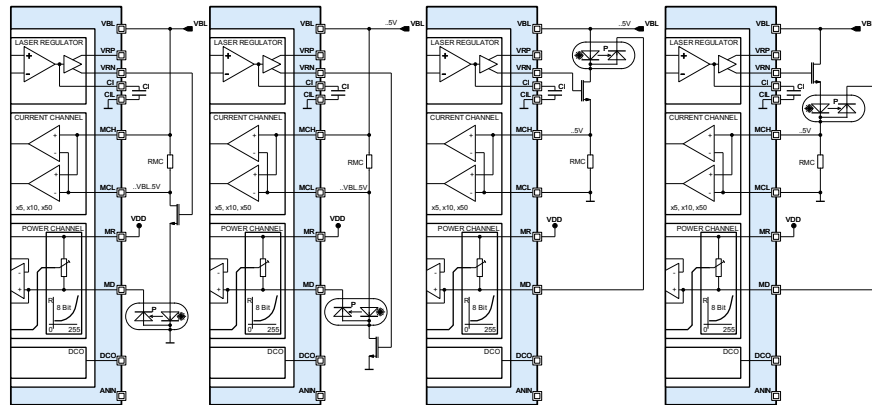

Figure 29: iC-HTG with N-channel output transistor and P-type laser diode

Register	Figure 29.a	Figure 29.b	Figure 29.c	Figure 29.d	EACC	ADCC
MCVR	1	1	0	0	1	011
EPNNP	1	1	1	1	0	100

Table 96: Configuration register for Figure 29

Note that in Figures 29.b and 29.c the VBL voltage is limited to 5 V.

iC-HTG POWER CW LASER DIODE DRIVER

Rev B1, Page 37/40

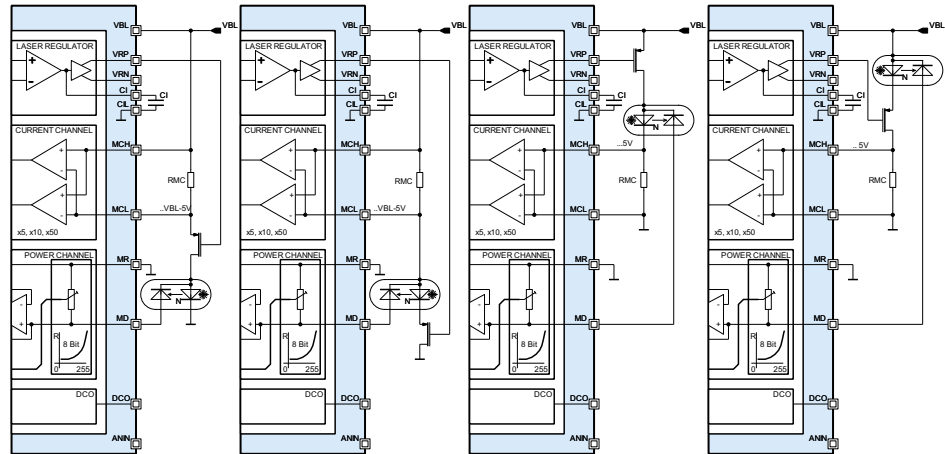

Figure 30: iC-HTG with P-channel output transistor and N-type laser diode.

Register	Figure 30.a	Figure 30.b	Figure 30.c	Figure 30.d	EACC	ADCC
MCVR	1	1	0	0	1	011
EPNNP	0	0	0	0	0	100

Table 97: Configuration register for Figure 30

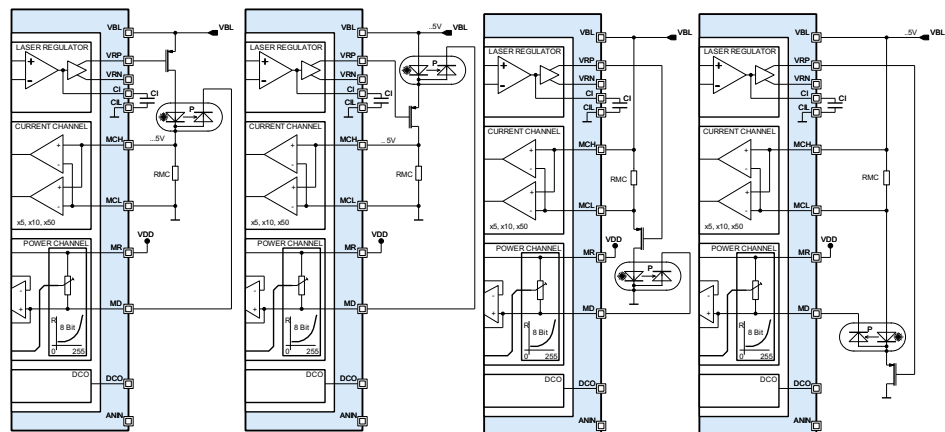

Figure 31: iC-HTG with P-channel output transistor and P-type laser diode

Register	Figure 31.a	Figure 31.b	Figure 31.c	Figure 31.d	EACC	ADCC
MCVR	0	0	1	1	1	011
EPNNP	1	1	1	1	0	100

Table 98: Configuration register for Figure 31

Note that in Figures 31.b and 31.d the VBL voltage is limited to 5 V.

iC-HTG POWER CW LASER DIODE DRIVER

Rev B1, Page 38/40

DESIGN REVIEW: Notes On Chip Functions

iC-HTG Z, Z1		
No.	Function, Parameter/Code	Description and Application Notes
1	NEBUF	For iC-HTG chip releases Z and Z1 it is NOT recommended to use NEBUF = 0. Otherwise, proper operation of the control loop can not be guaranteed for all conditions. The parameter NEBUF does not exist anymore with iC-HTG chip release Y or higher.
2	CHIPREV	For iC-HTG chip releases see Table 62.

Table 99: Notes on chip functions regarding iC-HTG chip release Z and Z1

iC-HTG Y, Y1		
No.	Function, Parameter/Code	Description and Application Notes
1	VRNHR	Voltage output range selection for VRN. More information on Table 86 and page 16.
2	CHIPREV	For iC-HTG chip releases see Table 62.

Table 100: Notes on chip functions regarding iC-HTG chip release Y and Y1

iC-HTG X		
No.	Function, Parameter/Code	Description and Application Notes
1	DRDY	Data Ready Status Register for A/D Synchronisation. More information on page 21.
2	ENADCDIV	Save current bit if voltage dividers are not used in AD. More information on page 21
3	LINLOG	Logarithmic DA converter can be set as linear one. More information on page 21
4	ESD	Internal ESD Protection under 500 V
5	CHIPREV	For iC-HTG chip releases see Table 62.
6	Permissible Supply Voltage at VB, Electrical Characteristics No. 001	VB = 10 V max.

Table 101: Notes on chip functions regarding iC-HTG chip release X

iC-HTG W1		
No.	Function, Parameter/Code	Description and Application Notes
1	CHIPREV	For iC-HTG chip releases see Table 62.

Table 102: Notes on chip functions regarding iC-HTG chip release W1

IC-HTG

POWER CW LASER DIODE DRIVER

Rev B1, Page 39/40

REVISION HISTORY

Rel.	Rel. Date†	Chapter	Modification	Page
A1	2017-11-24		Initial release	

Rel.	Rel. Date†	Chapter	Modification	Page
B1	2020-10-01	DESCRIPTION	Poti max. value changed form 500 to 407 kΩ	2
		ABSOLUTE MAXIMUM RATINGS	G005, G007: pin EC added	6
		ELECTRICAL CHARACTERISTICS	Operating Conditions: VB = VBL = 3 ... 24 V (relative to GND), Tj = -40 ... 125 °C unless otherwise stated	7-10
		ELECTRICAL CHARACTERISTICS	Specification Updated at Item No. 003, 006, 008, 012, 103, 303, 502 added and inserted, 304 ... 306, 107 ... 110, 402, 605, 609, 711, C03, D02 and E02	7-10
		STANDBY	Additional series resistor when connecting NSTY to VB	12
		OPERATION MODE	Renamed PDVDD => PDOVDD	13
		CONTROL MODES AND LASER DIODE/LED TYPES	New function Register VRNHR described	16
		8-BIT INTERNAL PROGRAMMABLE LOGARITHMIC MONITOR RESISTORS	Poti max. value changed form 500 to 407 kΩ	20
		10-BIT LOGARITHMIC D/A CONVERTER	New Linear Reference Mode described (introduced in HTG_X version)	20
		10-BIT LINEAR A/D CONVERTER	New register DRDY and ANADCDIV described. New method for synchronisation of the AD described. (introduced in HTG_X version)	21
		10-BIT LINEAR A/D CONVERTER	Readout advise added	22
		REGISTER OVERVIEW	Updated	29
		DESIGN REVIEW: Notes On Chip Functions	Chapters added	41

iC-Haus expressly reserves the right to change its products, specifications and related supplements (together the Documents). A Datasheet Update Notification (DUN) gives details as to any amendments and additions made to the relevant Documents on our internet website www.ichaus.com/DUN and is automatically generated and shall be sent to registered users by email.

Copying – even as an excerpt – is only permitted with iC-Haus' approval in writing and precise reference to source.

The data and predicted functionality is intended solely for the purpose of product description and shall represent the usual quality and behaviour of the product. In case the Documents contain obvious mistakes e.g. in writing or calculation, iC-Haus reserves the right to correct the Documents and no liability arises insofar that the Documents were from a third party view obviously not reliable. There shall be no claims based on defects as to quality and behaviour in cases of insignificant deviations from the Documents or in case of only minor impairment of usability.

No representations or warranties, either expressed or implied, of merchantability, fitness for a particular purpose or of any other nature are made hereunder with respect to information/specification resp. Documents or the products to which information refers and no guarantee with respect to compliance to the intended use is given. In particular, this also applies to the stated possible applications or areas of applications of the product.

iC-Haus products are not designed for and must not be used in connection with any applications where the failure of such products would reasonably be expected to result in significant personal injury or death (*Safety-Critical Applications*) without iC-Haus' specific written consent. Safety-Critical Applications include, without limitation, life support devices and systems. iC-Haus products are not designed nor intended for use in military or aerospace applications or environments or in automotive applications unless specifically designated for such use by iC-Haus.

iC-Haus conveys no patent, copyright, mask work right or other trade mark right to this product. iC-Haus assumes no liability for any patent and/or other trade mark rights of a third party resulting from processing or handling of the product and/or any other use of the product.

Software and its documentation is provided by iC-Haus GmbH or contributors "AS IS" and is subject to the ZVEI General Conditions for the Supply of Products and Services with iC-Haus amendments and the ZVEI Software clause with iC-Haus amendments (www.ichaus.com/EULA).

† Release Date format: YYYY-MM-DD

iC-HTG
POWER CW LASER DIODE DRIVER

Rev B1, Page 40/40

ORDERING INFORMATION

Type	Package	Order Designation
iC-HTG	QFN24 4 mm x 4 mm	iC-HTG QFN24-4x4
Evaluation Board	100 mm x 80 mm eval board	iC-HTG EVAL HTG1D

Please send your purchase orders to our order handling team.

For technical support, information about prices and terms of delivery please contact us.