



PART NUMBER

**FD1500W**

Large Area InGaAs PIN Photodiodes  
diameter of active area=1.5 mm

## DESCRIPTION

Large area, high sensitivity photodiode for use in infrared instrumentation and sensing applications. High spectral response in the region 800 nm to 1700 nm. The photosensitive area is 1.5 mm in diameter. Planar-passivated device structure.

## ABSOLUTE MAXIMUM RATINGS (T=25°C)

PARAMETER	RATING	UNITS
Storage Temperature	-40 to +100	°C
Operating Temperature	-40 to +85	°C
Forward Current	100	mA
Reverse Current	20	mA
Reverse Voltage	2	V

## OPTICAL AND ELECTRICAL CHARACTERISTICS (T=25°C)

PARAMETER	SYMBOL	TEST CONDITIONS	MIN	TYP	MAX	UNITS
Responsivity	R	$\lambda = 850 \text{ nm}$	0.10	0.20	-	A/W
		$\lambda = 1300 \text{ nm}$	0.80	0.90	-	
		$\lambda = 1550 \text{ nm}$	0.85	0.95	-	
Shunt Resistance <sup>1</sup>	$R_s$	$V_R=0V$	2	10	-	M $\Omega$
Capacitance	C	$V_R=0V$	-	300	450	pF

<sup>1</sup>Very High Shunt Resistance devices are available upon request.

## DIMENSIONAL OUTLINE

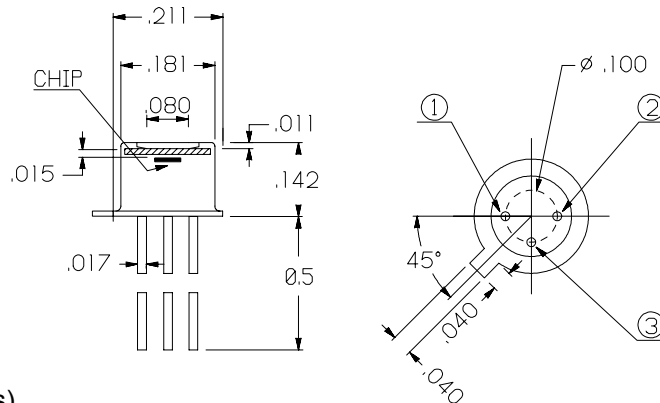

(dimensions in inches)

1	ANODE
2	CATHODE
3	CASE

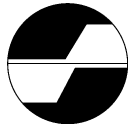

Large Area InGaAs PIN Photodiodes

**TYPICAL CHARACTERISTICS**

**Fig. 1 Spectral Response (R vs.  $\lambda$ )**

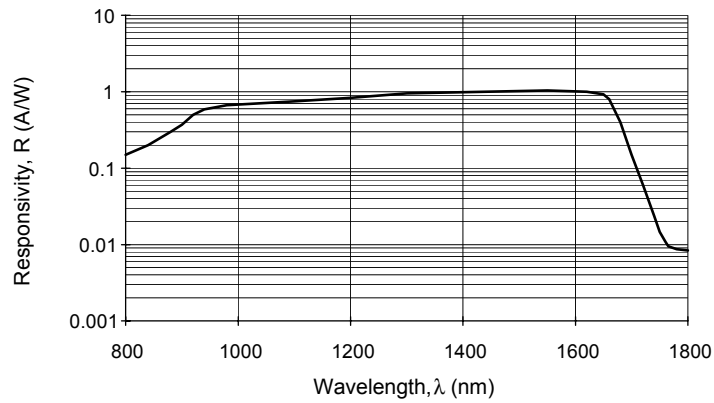

**Fig. 2 Dark Current vs. Reverse Voltage**

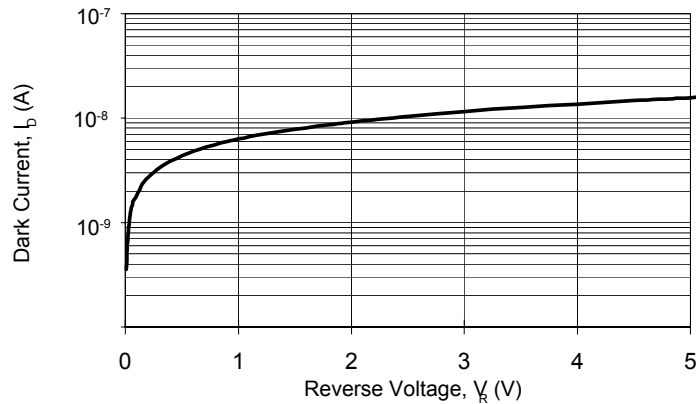

**Fig. 3 Capacitance vs. Reverse Voltage**

